

# Service Manual

Dolby NR-Equipped  
Double Cassette Deck

Cassette Deck  
**RS-D225W**

RS-D225W



Color

(K)...Black Type

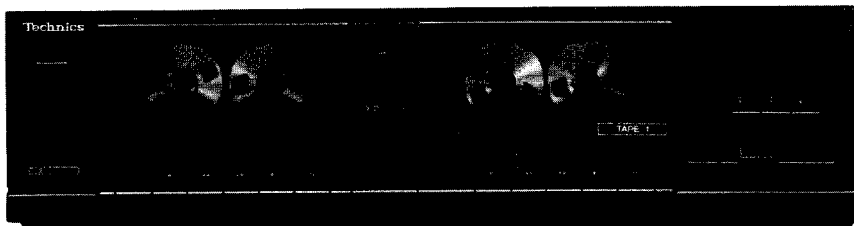

Color	Areas
(K)	[E].....All European areas except United Kingdom.
(K)	[EK].....United Kingdom.
(K)	[EH].....Holland.
(K)	[EGA]....F.R. Germany.
(K)	[EB].....Belgium.
(K)	[XA].....Asia, Oceania, Latin America, Middle Near East and Africa.
(K)	[XL].....Australia.

## RS-D550W MECHANISM SERIES

### SPECIFICATIONS

Deck system	Stereo cassette deck
Track system	4-track, 2-channel
Heads	
(TAPE 1) PLAY	Solid Permaloy head
(TAPE 2) REC/PLAY	Solid Permaloy head
(TAPE 2) Erasing	Double-gap ferrite head
Motors	
(TAPE 1) Capstan/reel table drive	2 speed electronically controlled DC motor
(TAPE 2) Capstan/reel table drive	2 speed electronically controlled DC motor
Recording system	AC bias
Bias frequency	80kHz
Tape speed	4.8cm/sec. (1-7/8ips)
Frequency response (w/o Dolby N.R.)	
METAL	20Hz~16kHz 30Hz~15kHz (DIN)
CrO <sub>2</sub>	20Hz~15kHz 30Hz~15kHz (DIN)
NORMAL	20Hz~15kHz 30Hz~15kHz (DIN)
S/N (signal level=max. recording level, CrO <sub>2</sub> type tape)	
Dolby NR in	66dB (CCIR)
NR out	56dB (A weighted peak)

Wow and flutter 0.08% (WRMS)  
±0.2% (DIN)

Fast forward and rewind time  
Approx. 105 seconds with C-60 cassette tape

Input sensitivity and impedance  
LINE 60mV/47kΩ

Output voltage and impedance  
LINE 400mV/1.5kΩ

#### ■ GENERAL

Power consumption 18W

Dimensions (W×H×D) 430×115×227 mm  
(16-15/16"×4-1/2"×9-1/32")

Weight 3.4 kg (7.5lb.)

\* Dolby noise reduction manufactured under license from Dolby Laboratories Licensing Corporation.  
"Dolby" and the double-D symbol are trade marks of Dolby Laboratories Licensing Corporation.

# Technics

Matsushita Electric Trading Co., Ltd.  
P.O. Box 288, Central Osaka Japan

# CONTENTS

	Page
• How To Connect .....	2
• Location of Controls.....	3
• Operation .....	4~6
• Disassembly Instructions .....	7
• Information on Power Supply Jig .....	8
• Measurement and Adjustment Methodes .....	9, 10
• Microcomputer Terminal Function and Waveform .....	11, 12

	Page
• Wiring Connection Diagram .....	13, 14
• Printed Circuit Boards .....	15~17
• Resistors and Capacitors .....	18
• Block Diagram.....	19, 20
• Electrical Parts List .....	21
• Schematic Diagram.....	21~24
• Mechanical Parts Location.....	25, 26
• Cabinet Parts Location .....	27, 28

## HOW TO CONNECT

Connect the turntable, tuner, amplifier, cassette deck, and CD player as shown.

If the connection is wrong, normal operation will not be attained.

Tuner (ST-Z990/Z990L) and Cassette deck (RS-D225W) is not equipped with power supply. So, the amplifier shown or power supply JIG is necessary for the repair and check of Tuner or Cassette deck.

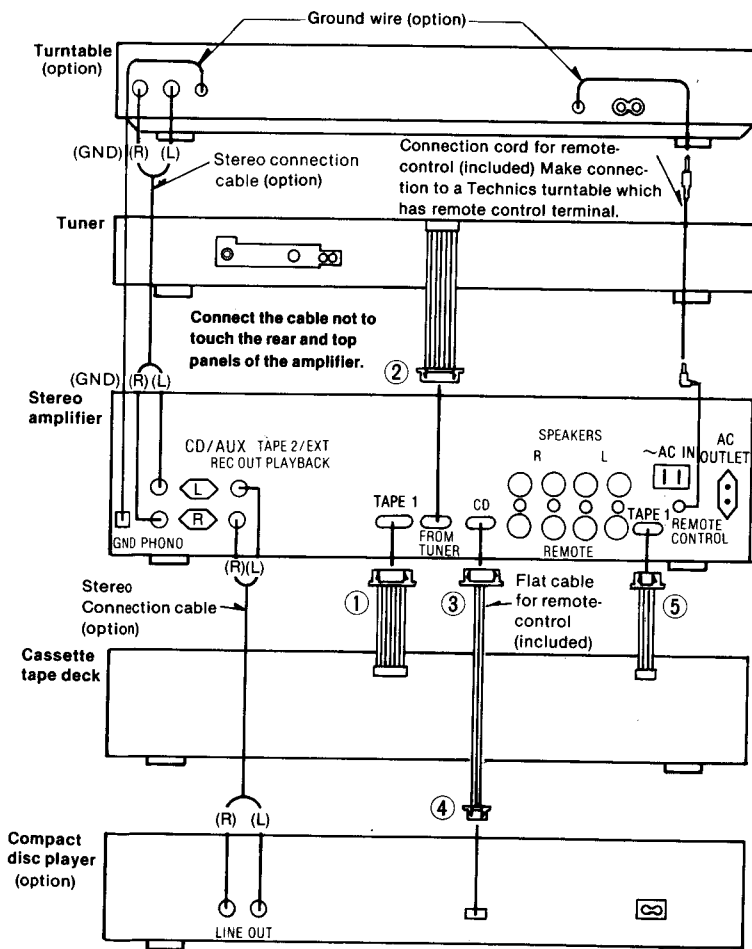

※ Flat cables for remote-control should be connected correctly. If connections are wrong, the units do not function correctly.

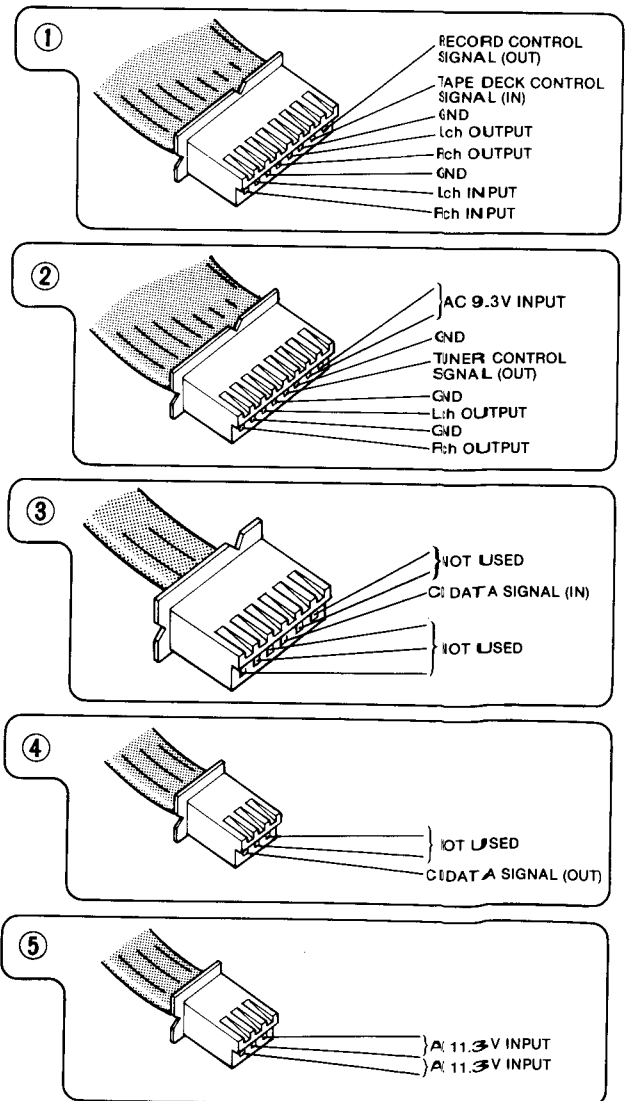

Dolby NR-Equipped Double Cassette Deck

**RS-D225W****DEUTSCH**

DEUTSCH

**MESSUNGEN UND JUSTIERUNGEN****Meßinstrumente**

- Elektronisches Voltmeter (EVM)
- Oszilloskop
- Digitaler Frequenzmesser
- Audiofrequenz-Oszillator
- Dämpfungswiderstand
- Gleichstrom-Voltmeter
- Widerstand (600Ω)

**Kopfazimut-Justierung (TAPE 1. 2)**

1. Die Anschlußverbindungen für die Testgeräte sind in Abb. 1 gezeigt.
2. Den Azimut-Justierungsteil (8kHz, -20dB) des Testbandes (QZZCFM) wiedergeben und die Winkeljustierungs-Einstellschraube so verstellen, daß der Ausgang vom linken und rechten Kanal maximal wird. (Wenn die Justierpositionen für den linken und rechten Kanal verschieden sind, ist eine Position zu finden, wo der Ausgang des linken und rechten Kanals ausgeglichen ist, und dann ist die Justierung durchzuführen.)
3. Gleichzeitig eine Lissajous-Wellenform ziehen und Phasenablenkung eliminieren.
4. Nach erfolgter Justierung sind die Bandführungs-Höhen-und-Winkeljustierschrauben zu sichern.



Abb. 2



Abb. 1

**Bandgeschwindigkeits-Justierung (TAPE 1. 2)****Normalgeschwindigkeit**

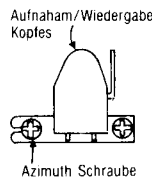
1. Der Testaufbau ist in Abb. 3 gezeigt.
2. Den mittleren Teil des Testbandes (QZZCWAT) wiedergeben.
3. Den Drehwiderstand 904 für TAPE 1 und den Drehwiderstand 903 für TAPE 2 so justieren, daß die Ausgangsleistung dem Standard-Wert entspricht.

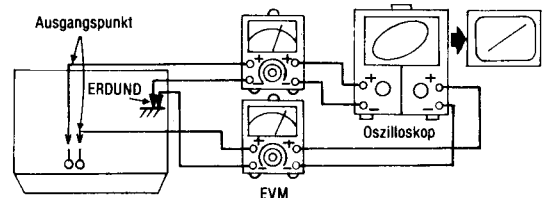

Abb. 3

**Hohe Geschwindigkeit**

4. Den kopiergeschwindigkeits-Wahlschalter auf "×2" stellen und TAPE 1: TP1 und TPN1 sowie TAPE 2: TP2 und TPN2 kurzschließen.
5. Den mittleren Teil des Testbandes (QZZCWAT) wiedergeben.
6. Den Drehwiderstand 902 für TAPE 1 und den Drehwiderstand 901 für TAPE 2 so justieren daß die Ausgangsleistung dem Standard-Wert entspricht.

**Standard-Wert: 3000 ± 20 Hz (Normal), 6000 ± 40 Hz (High)**

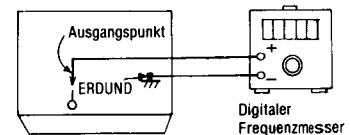
**Wiedergabe-Frequenzgang (TAPE 1. 2)**

1. Der Testaufbau ist in Abb. 4 gezeigt.
2. Den Wiedergabe-Frequenzgangteil (315Hz, 12,5kHz~63Hz, -20dB) des Testbandes (QZZCFM) wiedergeben.
3. Überprüfen, ob der Frequenzgang innerhalb des in Abb. 5 für den linken und rechten Kanal gezeigten Bereichs liegt.



Abb. 4



Abb. 5

### Justierung des Wiedergabe-Verstärkungsgrades (TAPE 1. 2)

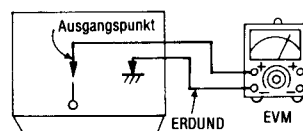
1. Der Testaufbau ist in Abb. 4 gezeigt.
2. Den für den Wiedergabe-Verstärkungsgrad justierten Teil (315Hz, 0dB) des Testbandes (QZZCFM) wiedergeben.
3. Den Drehwiderstand 1, (linker Kanal) {Drehwiderstand 2 (rechter Kanal)} für TAPE 1 und den Drehwiderstand 3, (linker Kanal) {Drehwiderstand 4 (rechter Kanal)} für TAPE 2 so justieren, daß die Ausgangsleistung dem Standard-Wert entspricht.

**Standard-Wert:  $0,4V \pm 0,5dB$  (0,02V)**

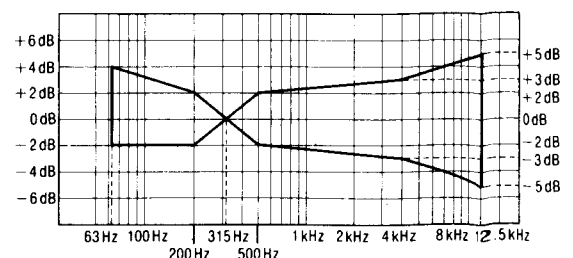
### Gesamtfrequenzgang (TAPE 2)

1. Der Testaufbau ist in Abb. 6 gezeigt, eine kurzschlußbrücke an TP6 legen.
2. Eine Normalband-Leercassette (QZZCRA) einsetzen und aufnehmen, während ein Signal von nacheinander 50Hz, 100Hz, 200Hz, 500Hz, 1kHz, 4kHz, 8kHz, und 10kHz bei 20dB, abgeschwächt vom Referenz-Eingangssignalsignal (1kHz, -24dB) eingegeben wird.
3. Das in Schritt 2 aufgezeichnete Signal wiedergeben und prüfen, ob der Pegel jeder Ausgangsfrequenz im Bereich liegt, der in Abb. 7 im Vergleich zur Referenzfrequenz (1kHz) gezeigt wird.
4. Falls er nicht im Standard-Bereich liegt, ist der Vormagnetisierungsstrom mit Drehwiderstand 301 (linker Kanal) {Drehwiderstand 302 (rechter Kanal)} so zu justieren, daß der Frequenzpegel innerhalb des Standards zu liegen kommt.
  - Erhöhter Pegel im Frequenzbereich..... Den Vormagnetisierungsstrom erhöhen.
  - Reduzierter Pegel im Frequenzbereich..... Den Vormagnetisierungsstrom senken.
5. Anschließend das auf der CrO2-Leerband-Cassette (QZZCRX) und der Reineisenband-Leercassette (QZZCRZ) aufgezeichnete Signal auf 12,5kHz erhöhen und auf gleiche Weise justieren, wie vorgehend beschrieben. Dann überprüfen, ob der Frequenzpegel innerhalb des in Abb. 8 gezeigten Bereichs liegt.
6. Nach der Justierung ist die kurzschlußbrücke von TP6 zu trennen.



Abb. 6



Abb. 7

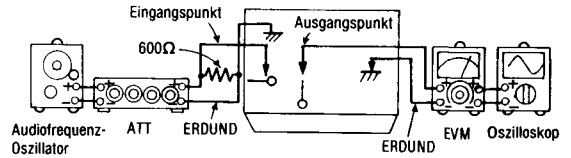

Abb. 8

### Justierung des Gesamtverstärkungsgrades (TAPE 2)

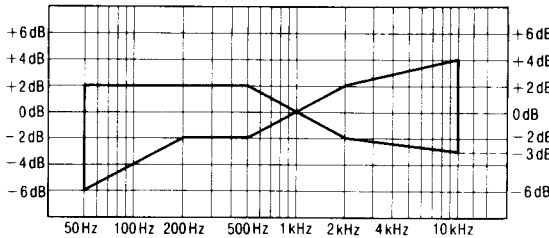
1. Der Testaufbau ist in Abb. 6 gezeigt, eine kurzschlußbrücke an TP6 legen.
2. Eine Normalband-Leercassette (QZZCRA) einsetzen und im Aufnahme-pause-Zustand des Gerätes das Referenzsignal (1kHz, -24dB) eingeben.
3. Die Ausgangsleistung mit dem Dämpfungswiderstand auf 0.4V justieren und dann aufnehmen.
4. Das in Schritt 3 aufgezeichnete Signal wiedergeben und überprüfen, ob die Ausgangsleistung dem Standard-Wert entspricht.
5. Falls sie nicht dem Standard-Wert entspricht, ist der Drehwiderstand 7 (linker Kanal) {Drehwiderstand 8 (rechter Kanal)} zu justieren, und dann sind die Schritte (2), (3) und (4) zu Wiederholen, bis die Ausgangsleistung dem Standard-Wert entspricht.
6. Nach der Justierung ist die kurzschlußbrücke von TP6 zu trennen.

**Standard-Wert:  $0,4^{+0,1}_{-0,08} V$**

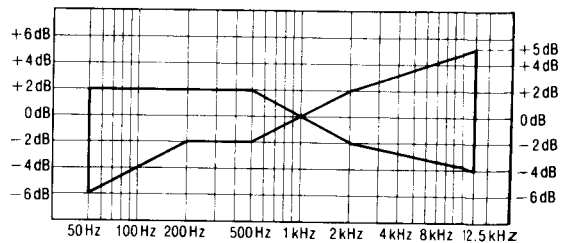
### Dolby-Rauschunterdrückungs-Schaltkreis

1. Der Testaufbau ist in Abb. 9 gezeigt.
2. Eine Normalband-Cassette einsetzen und im Aufnahme-pause-Zustand des Gerätes ein 5kHz-Signal eingeben.
3. Mit dem Dämpfungswiderstand so justieren, daß die Ausgangsleistung zwischen Anschluß ⑥ (linker Kanal) {Anschluß ⑨ (rechter Kanal)} des IC401 und Masse 12,3mV beträgt.
4. Den Rauschunterdrückungs-Schalter (NR) einschalten und prüfen, ob der Pegel wie vorgeschrieben gegenüber dem Pegel im rauschunterdrückungsfreien Zustand verändert wird.



Abb. 9

**Standard-Wert:  $8 \pm 1,5dB$**

## MESURAGES ET REGLAGES

### Appareils de mesure

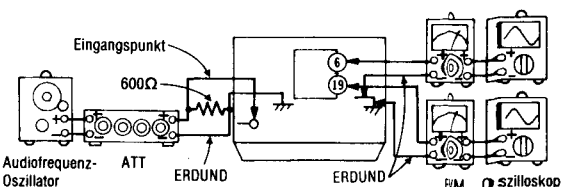
- Voltmètre électronique
- Oscilloscope
- Compteur de fréquence numérique
- Oscillateur de fréquence audio

- A.T.T. (Atténuateur)
- Voltmètre à C.C.
- Résistance (600Ω)

### Réglage de l'angle des têtes de lecture (BANDE 1. 2)

1. Le raccordement de l'équipement d'essai est montré à la Fig. 1.
2. Faire jouer la partie réglée azimutale (8kHz, -20dB) de la bande d'essai (QZZCFM) et régler la vis de mise au point azimutale de telle sorte que les puissances de sortie du canal de gauche et du canal de droite soient au maximum.  
(Si les positions de réglage du canal de gauche et du canal de droite sont différentes, trouver une position où les puissances de sortie des canaux de gauche et de droite soient équilibrées, puis effectuer la mise au point.)
3. En même temps, établir une forme d'onde de Lissajous et éliminer la déviation de phase.
4. Après le réglage, bloquer les vis du réglage angulaire et de la hauteur des guides de bande.

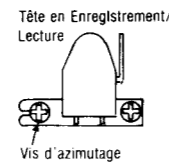

Fig. 2

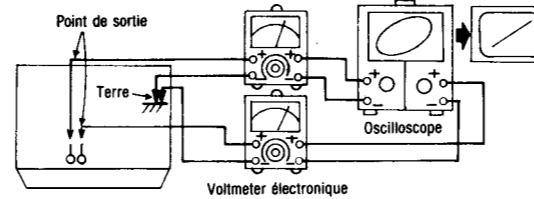

Fig. 1

### Réglage de la vitesse de défilement de la bande (BANDE 1. 2)

#### Vitesse de défilement normale

1. Le raccordement de l'équipement d'essai est montré à la Fig. 3.
2. Faire jouer la partie centrale de la bande d'essai (QZZCWAT).
3. Régler La BANDE 1: VR904 et la BANDE 2: VR903 de telle sorte que la puissance de sortie soit en deçà de la normale.

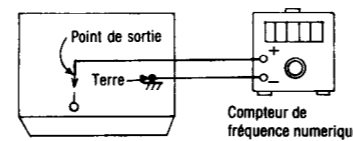

Fig. 3

#### Vitesse de défilement élevée

4. Régler le commutateur de vitesse du montage sur "x2" et court-circuiter la BANDE 1; TP1 et TPN1 et la BANDE 2; TP2 et TPN2.
5. Faire jouer la partie centrale de la bande d'essai (QZZCWAT).
6. Régler La BANDE 1: VR902 et la BANDE 2: VR901 de telle sorte que la puissance de sortie soit en deçà de la normale.

Valeur normalisée: 3000 ± 20 Hz (Normale), 6000 ± 40 Hz (Elevée)

### Réponse en fréquence de la lecture (BANDE 1. 2)

1. Le raccordement de l'équipement d'essai est montré à la Fig. 4.
2. Faire jouer la partie de la réponse en fréquence de la lecture (315Hz, 12,5kHz~63Hz, -20dB) de la bande d'essai (QZZCFM).
3. Vérifier que la fréquence soit en deçà de la plage montrée à la Fig. 5, à la fois pour le canal de gauche et le canal de droite.

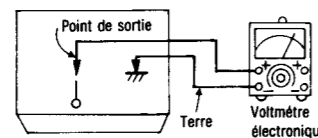

Fig. 4

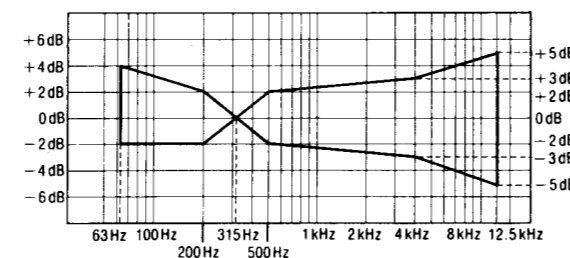

Fig. 5

### Réglage d'amplification de la lecture (BANDE 1. 2)

1. Le raccordement de l'équipement d'essai est montré à la Fig. 4.
2. Faire jouer la partie réglée d'amplification de la lecture (315Hz, 0dB) de la bande d'essai (QZZCFM).
3. Régler la BANDE 1: VR1 (canal de gauche) [VR2 (canal de droite)] et la BANDE 2: VR3, (canal de gauche) [VR4 (canal de droite)] de telle sorte que la puissance de sortie soit en deçà de la normale.

Valeur normalisée: 0,4 ± 0,5dB (0,02V)

### Réponse en fréquence globale (BANDE 2)

1. Le raccordement de l'équipement d'essai est montré à la Fig. 6, Raccorder un fil de connexion à TP6.
2. Installer une bande vierge normale (QZZCRA) et enregistrer en appliquant un signal (50Hz, 100Hz, 200Hz, 500Hz, 1kHz, 4kHz, 8kHz et 10kHz) de 20dB atténués provenant du signal du niveau d'entrée de référence (1kHz, -24dB).
3. Faire jouer le signal enregistré à l'étape 2 et vérifier que le niveau de chaque fréquence de sortie soit en deçà de la plage montrée à la Fig. 7 en comparaison avec la fréquence de référence (1kHz).
4. S'il n'est pas en deçà de la plage standard, régler le courant de polarisation avec VR 301 (canal de gauche) [VR302 (canal de droite)], de telle sorte que le niveau de fréquence soit en deçà de la normale.
  - Niveau vers la haut dans la plage de fréquence élevée..... Augmenter le courant de polarisation.
  - Niveau vers le bas dans la plage de fréquence élevée..... Diminuer le courant de polarisation.
5. Après cela, amplifier le signal enregistré sur la bande vierge CrO2 (QZZCRX) et la bande vierge métallisée (QZZCRZ) jusqu'à 12,5kHz et régler de la même manière que celle mentionné ci-dessus. Puis, vérifier que le niveau de fréquence soit en deçà de la plage montrée à la Fig. 8.
6. Après le réglage, couper le fil de connexion de TP6.

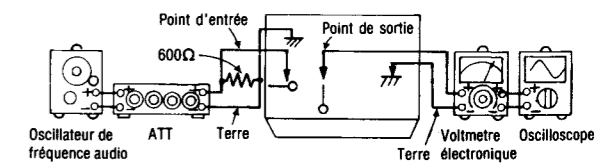

Fig. 6

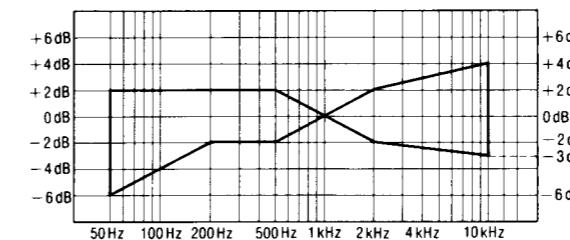

Fig. 7

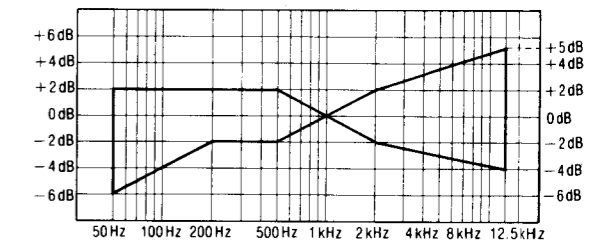

Fig. 8

### Réglage d'amplification globale (BANDE 2)

1. Le raccordement de l'équipement d'essai est montré à la Fig. 6, Raccorder un fil de connexion à TP6.
2. Installer une bande vierge normale (QZZCRA) et appliquer le signal de niveau d'entrée de référence (1kHz, -24dB) sur le mode d'intermission d'enregistrement.
3. Régler la puissance de sortie 0.4V avec L'atténuateur, puis enregistrer.
4. Faire jouer le signal enregistré à l'étape 3 et vérifier que la puissance de sortie soit en deçà de la normale.
5. Si elle n'est pas en deçà de la normale, régler VR7 (canal de gauche) [VR8 (canal de droite)] et répéter les étapes (2), (3) et (4) jusqu'à ce que la puissance de sortie soit en deçà de la normale.
6. Après le réglage, couper le fil de connexion de TP6.

Valeur normalisée: 0.4<sup>+0,1</sup><sub>-0,08</sub> V

### Circuit de réduction des bruits Dolby

1. Le raccordement de l'équipement d'essai est montré à la Fig. 9.
2. Installer une bande normale et appliquer un signal de 5kHz sur le mode d'intermission d'enregistrement.
3. Régler avec l'atténuateur de telle sorte que la puissance de sortie entre la borne ⑥ (canal de gauche) [borne ⑨ (canal de droite)] de IC401 et la masse soit de 12,3mV.
4. Mettre en marche le commutateur de réduction des bruits et vérifier que le niveau change tel qu'il est spécifié à partir du niveau d'entrée sur le mode de sortie de réduction des bruits.

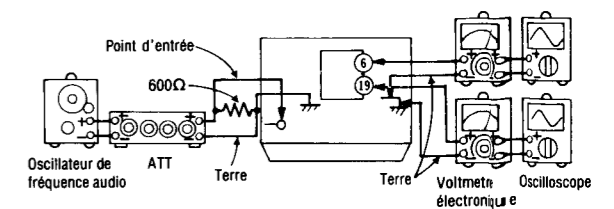

Fig. 9

Valeur normalisée: 8 ± 1,5dB

## MEDICIONES Y AJUSTE

### Instrumento de medición

- EVM (Voltmetro electrónico)
- Osciloscopio
- Frecuencímetro digital
- Oscilador AF

- ATT (Atenuador)
- Voltmetro CC
- Resistor (600Ω)

### Ajuste acimutal de cabeza (CINTA 1. 2)

1. La conexión del equipo de prueba se muestra en la Fig. 1.
2. Reproducir la parte ajustada de acimut (8kHz, -20dB) de la cinta de prueba (QZZCFM) y regular el tornillo de ajuste de ángulo de manera que las salidas de CH-I y CH-D sean maximizadas.

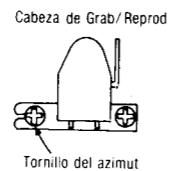

Fig. 2

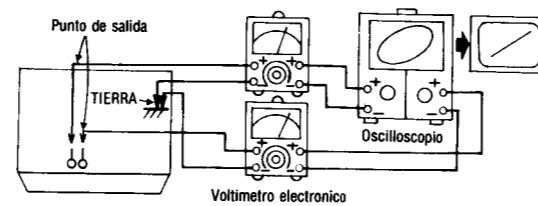

Fig. 1

- (Cuando las posiciones de ajuste sean diferentes de CH-I y CH-D, encontrar una posición donde las salidas de CH-I y CH-D estén equilibradas y, luego, hacer el ajuste.)
3. Al mismo tiempo, trazar una forma de onda de Lissajous y eliminar la deflexión de fase.
  4. Después del ajuste, fije los tornillos de ajuste de altura y ángulo de guía de cinta.

### Ajuste de velocidad de cinta (CINTA 1. 2)

#### Velocidad normal

1. La conexión del equipo de prueba se muestra en la Fig. 3
2. Reproducir la parte media de la cinta de prueba (QZZCWAT).
3. Ajustar La CINTA 1: RV904 y la CINTA 2: RV 903 de manera que la salida esté dentro del la estandar.

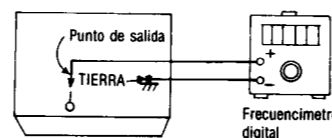

Fig. 3

#### Alta velocidad

4. Ajuste el conmutador de velocidad de montaje en "x2" y ponga en cortocircuito la CINTA 1; TP1 y TPN1 y la CINTA 2; TP2 y TPN2.
5. Reproducir la parte media de la cinta de prueba (QZZCWAT).
6. Ajustar La CINTA 1: RV902 y la CINTA 2: RV901 de manera que la salida esté dentro de la estandar.

Valor estandar: 3000 ± 20 Hz (Normal), 6000 ± 40 Hz (Alto)

### Respuesta de frecuencia de reproducción (CINTA 1. 2)

1. La conexión del equipo de prueba se muestra en la Fig. 4.
2. Reproducir la parte de respuesta de frecuencia de reproducción (315Hz, 12,5kHz~63Hz, -20dB) de la cinta de prueba (QZZCFM).
3. Comprobar que la frecuencia esté dentro de la gama mostrada en la Fig. 5 tanto para CH-I como para CH-D.

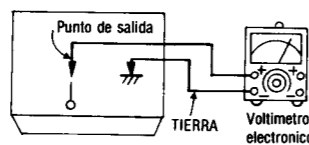

Fig. 4

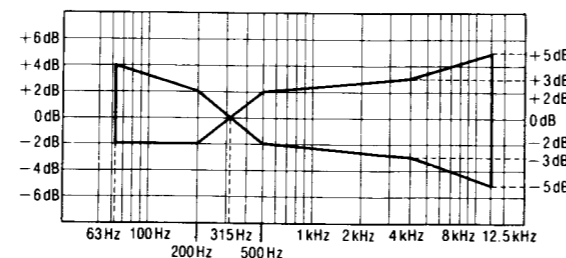

Fig. 5

### Ajuste de ganancia de reproducción (CINTA 1. 2)

1. La conexión del equipo de prueba se muestra en la Fig. 4.
2. Reproducir la parte ajustada de la ganancia de reproducción (315Hz, 0dB) de la cinta de prueba (QZZCFM).
3. Ajustar la CINTA 1: RV1 (CH-I) (RV2 (CH-D)) y la CINTA 2: RV3, (CH-I) (RV4 (CH-D)) de manera que la salida esté dentro de la estandar.

Valor estandar: 0,4 ± 0,5 dB (0,02 V)

### Respuesta de frecuencia total (CINTA 2)

1. La conexión del equipo de prueba se muestra en la Fig. 6, Conectar un hilo de puente de TP6.
2. Colocar una cinta virgen normal (QZZCRA) y grabar aplicando señal (50Hz, 100Hz, 200Hz, 500Hz, 1kHz, 4kHz, 8kHz y 10kHz), 20dB atenuada de la señal de nivel de entrada de referencia (1kHz, -24dB).
3. Reproducir la señal grabada en el paso 2 y comprobar que el nivel de cada frecuencia de salida esté dentro de la gama mostrada en la Fig. 7 en comparación con la frecuencia de referencia (1kHz).
4. Si no está dentro de la gama estandar, ajustar la corriente de polarización mediante RV301 (CH-I) (RV302 (CH-D)) de manera que el nivel de frecuencia esté dentro del estandar.
  - Subir el nivel en la gama de alta frecuencia..... Incrementar la corriente de polarización.
  - Bajar el nivel en la gama de alta frecuencia..... Disminuir la corriente de polarización.
5. Después de eso, incrementar la señal grabada en la cinta virgen CrO2 (QZZCRX) y la cinta virgen metálica (QZZCRZ) hasta 12,5kHz y ajustar de la misma manera como mencionado arriba y comprobar que el nivel de frecuencia esté dentro de la gama mostrada en la Fig. 8.
6. Después del ajuste, cortar un hilo de puente de TP6.

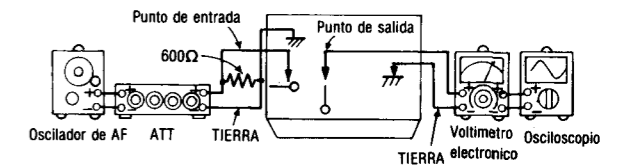

Fig. 6

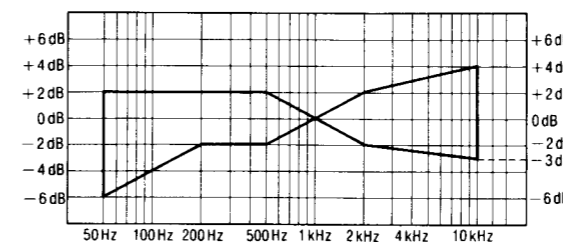

Fig. 7

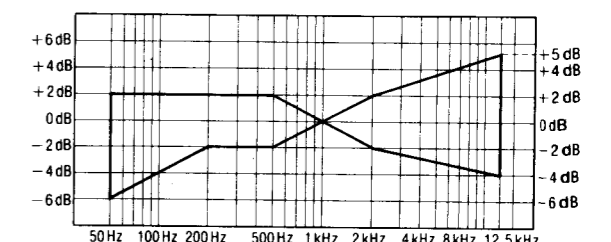

Fig. 8

### Ajuste de ganancia total (CINTA 2)

1. La conexión del equipo de prueba se muestra en la Fig. 6, Conectar un hilo de puente de TP6.
2. Colocar una cinta virgen normal (QZZCRA) y aplicar la señal de nivel de entrada de referencia (1kHz, -24dB) en la modalidad de pausa de grabación.
3. Ajustar la salida 0.4V mediante atenuador y, luego, grabar.
4. Reproducir la señal grabada en el paso 3 y comprobar que la salida esté dentro de la estandar.
5. Si no está dentro de la estandar, ajustar RV7 (CH-I) (RV8 (CH-D)) y repetir el paso (2), (3) y (4) hasta que la salida esté dentro de la estandar.
6. Después del ajuste, cortar un hilo de puente de TP6.

Valor estandar: 0,4<sup>+0,1</sup><sub>-0,08</sub> V

### Circuito RR Dolby

1. La conexión del equipo de prueba se muestra en la Fig. 9.
2. Colocar una cinta normal y aplicar señal 5kHz en la modalidad de pausa de grabación.
3. Ajustar mediante atenuador de manera que la salida entre terminal ⑥ (CH-I) (terminal ⑨ (CH-D)) de IC401 y tierra sea 12,3mV.
4. Prender el interruptor RR y comprobar que el nivel cambia como especificado por el nivel en la modalidad de salida RR.

Valor estandar: 8 ± 1,5 dB

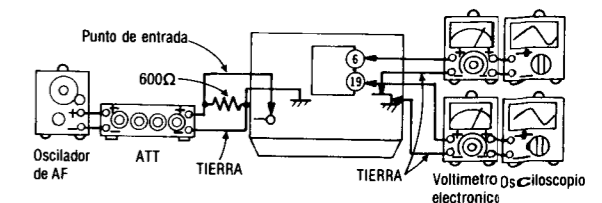
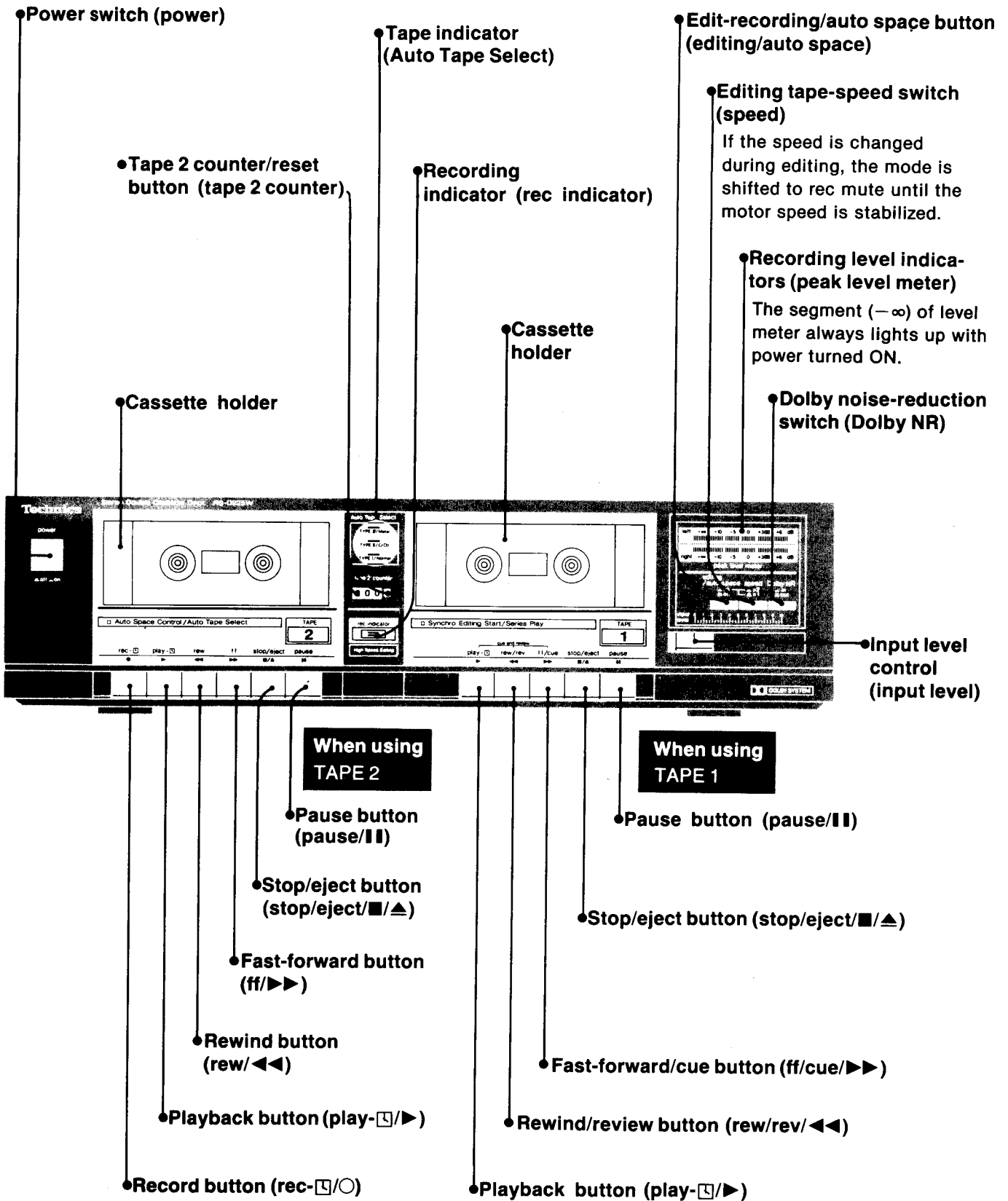

Fig. 9



## ■ LOCATION OF CONTROLS







## ■ OPERATION



# To Listen to Tapes

**3 "tape 1"**  
(The indicator will illuminate.)

**2 "off" (  →  )**

**4 Power: "on" (  →  )**

**1 "out" (  →  ):**  
Playing back tapes which were not recorded through the Dolby noise-reduction system.

**"in" (  →  ):**  
Playing back tapes which were recorded through the Dolby noise-reduction system

Amplifier  
(SU-Z990)

Tape deck  
(RS-D225W)

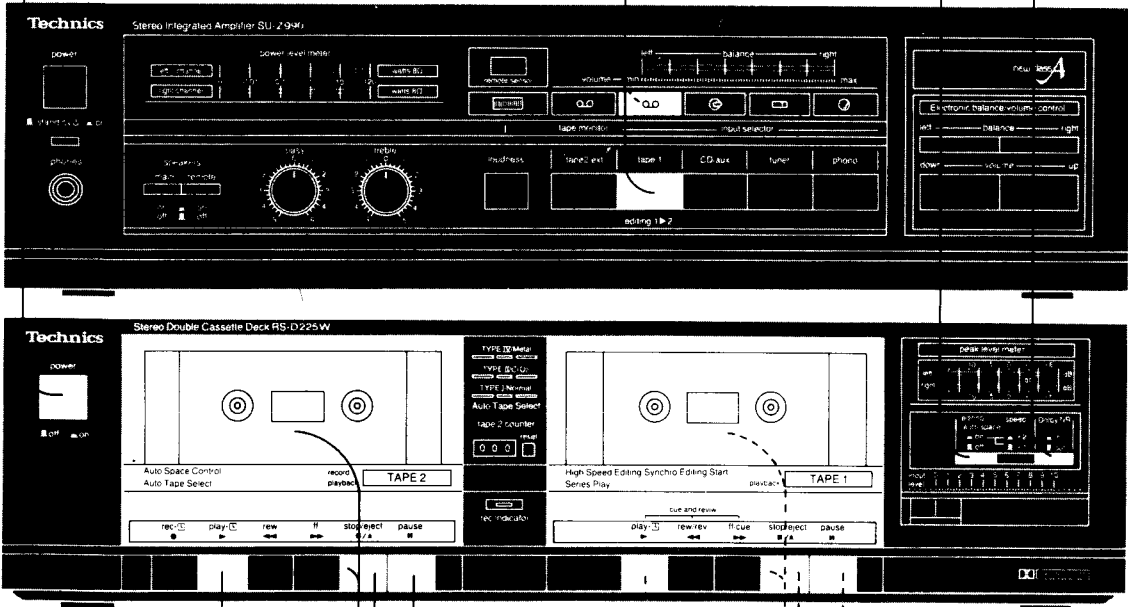

**When using TAPE 2**

Press to stop the tape temporarily.

Press to stop the tape.

**5 Press, then insert the tape cassette.**

**6 Press.**  
(Playback will begin.)

**7 Adjust the volume level and the desired tone quality.**

**When using TAPE 1**

Press to stop the tape temporarily.

Press to stop the tape.

**5 Press, then insert the tape cassette.**

**6 Press.**  
(Playback will begin.)

The side to be played back facing outward.

Part where tape is exposed facing downward.

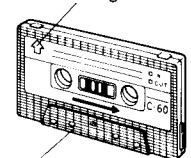

If the tape does not run in step 6 (For TAPE 1 and TAPE 2)  
Press the "play" button on the remote-control transmitter.

### Note:

TAPE 2 cannot be used for fast forward or rewind operations while TAPE 1 is being used for playback, although TAPE 1 can be used for fast forwarding and rewinding while TAPE 2 is being used for playback.

## To playback the tape by using the remote-control transmitter

1. Press the playback button of cassette deck.
2. Press the "play" button on the remote-control transmitter.
- To stop the playback temporarily:  
Press the "stop" button on the remote-control transmitter.  
To start the playback again, press the "play" button on the remote-control transmitter.



# Recording

**Note:**

Only TAPE 2 can be used for recording. TAPE 1 has no record capability.

**To make non-recorded spaces between tunes**

With this unit, by following the steps below, it is possible to make non-recorded spaces (four seconds long) between tunes.

● Press the edit-recording/auto space button.

(After about 4 seconds, the deck will automatically change to the recording stand-by mode. To resume the recording, set the button to the "off" position.)

**2 Press, then insert the tape cassette.**

The side to be recorded facing outward.

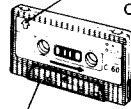

Part where tape is exposed facing downward.

**3 Power: "on" ( → )**

**1 Select the sound source.**

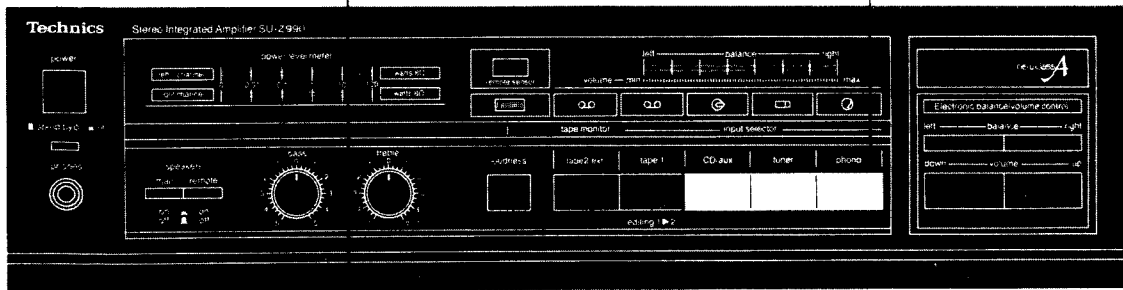

Amplifier (SU-Z990)

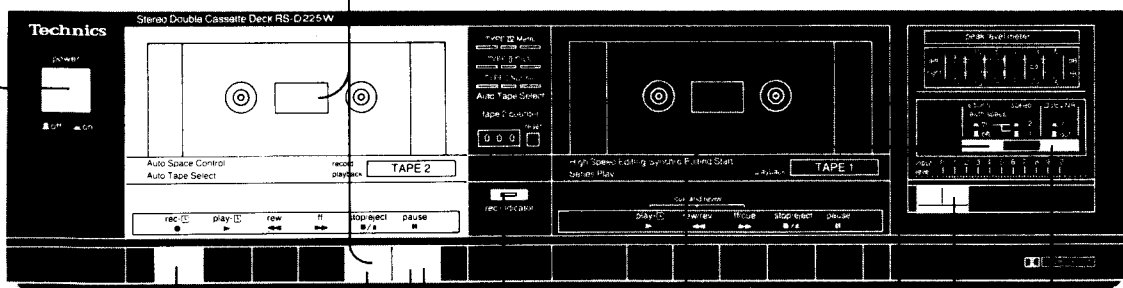

Tape deck (RS-D225W)

Press to stop the recording.

Recording indicator

Press to make non-recorded spaces between tunes.

**6 Press.**

Press the button to stop the recording temporarily.

**5 "off" ( → )**

**8 Start the desired program source.**

**4 "out" ( → ):**

Tape recording without the Dolby NR system.

**"in" ( → ):**

Tape recording with the Dolby NR system.

**7 Press.**  
(Recording stand-by mode)  
(The recording indicator will be illuminated.)

**9 Adjust the recording level.**

**10 Press.**  
(Recording will begin.)

**When the recording level cannot be adjusted**

The recording level might not be adjustable when the stop button on the remote-control transmitter is pressed.

If this happens, press the "play" button on the remote-control transmitter.

## To record by using the remote-control unit

1. Press the "rec" button on the deck itself.
2. Press the "play" button on the remote-control unit.
- To stop the recording temporarily:  
Press the "stop" button on the remote-control unit.  
(After about 4 seconds, the deck will automatically change to the recording stand-by mode.)

To start the recording again, press the "play" button on the remote-control unit.

## Adjustment of the recording level

The numbers which you should use as a guide for the adjustment of the tape level will differ depending upon the type of tape.

Normal Tape CrO <sub>2</sub> Tape	Metal Tape
+3 dB	+6 dB

## Dolby noise-reduction systems

Because the level of tape noise is a fixed level, such noise is more easily heard as the level of the music signals becomes lower. Thus, when a recording is made, low levels are recorded at a high level, and, when this recording is played back, it is played back, conversely, at a low level. Because the tape noise will also be then played back at a low level, the result is a reduction in the noise level.

- Dolby noise reduction system manufactured under license from Dolby Laboratories Licensing Corporation.
- "Dolby" and the double-D symbol are trademarks of Dolby Laboratories Licensing Corporation.

## Automatic tape selector system

This cassette deck automatically detects the type of tape being used, and adjusts for the proper bias and equalization.

When tape deck 2 is used, the tape indicator illumination will correspond to the type of tape used in tape deck 2.

## Series playback

Playback is continuous from tape deck 1 to tape deck 2 (or from tape deck 2 to tape deck 1).

### When starting from tape deck 2

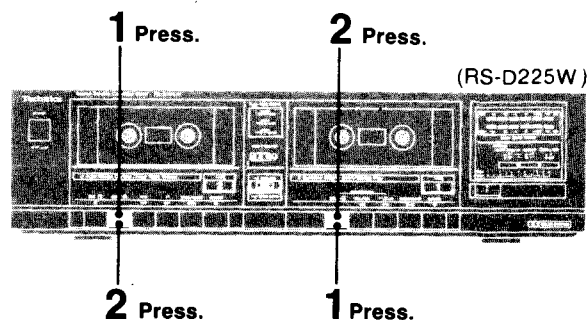

### When starting from tape deck 1

## Edit-Recording

- The remote-control unit cannot be used for tape operation during edit recording.
- To make non-recorded space (about four seconds long)

between tunes, press the stop button for tape deck 1. (The restart of the recording can be started by pressing the playback button once again.)

### Preparations for recording

- 1 Power: "on" (I → II)
- 2 Press, then insert the tape to be used for recording.

### Preparations for playback

- 3 Press, then insert the recorded tape to be played back.
- 4 "on" (I → II)
- 5 Select the tape speed.
  - × 2...at double speed.
  - × 1...at normal speed.

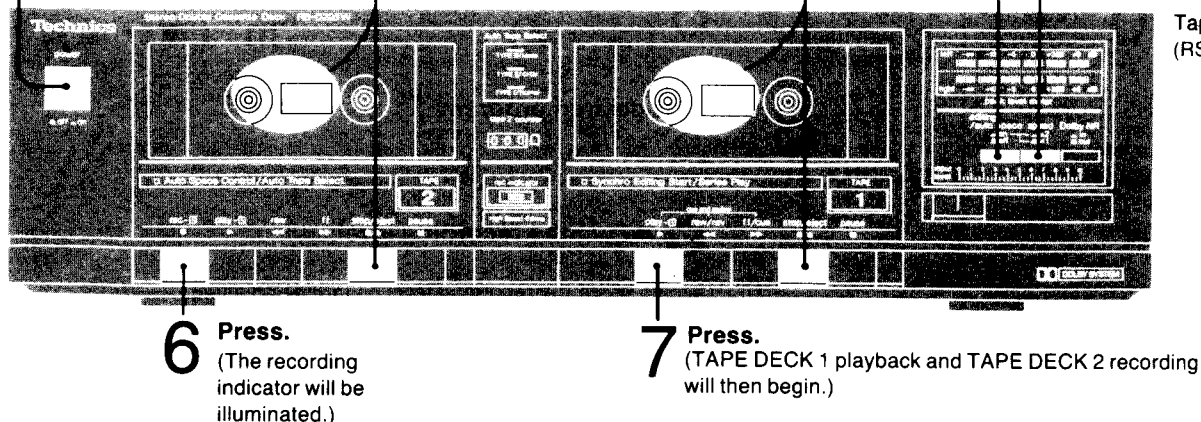

- 6 Press. (The recording indicator will be illuminated.)

- 7 Press. (TAPE DECK 1 playback and TAPE DECK 2 recording will then begin.)

## ■ DISASSEMBLY INSTRUCTIONS

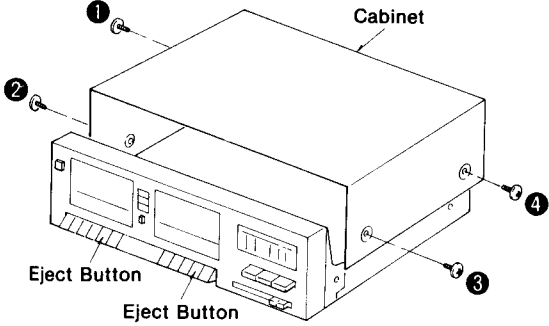
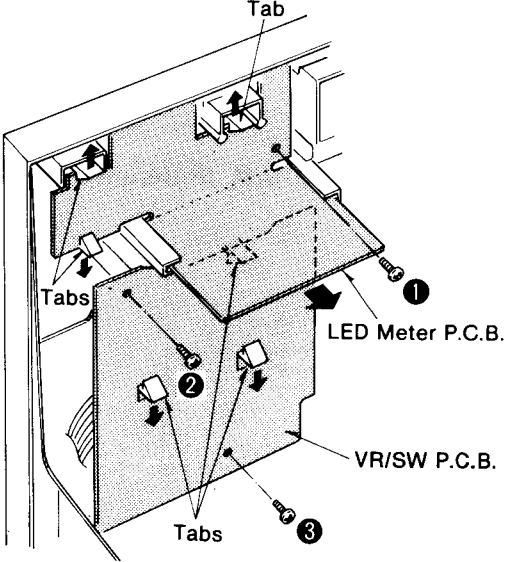
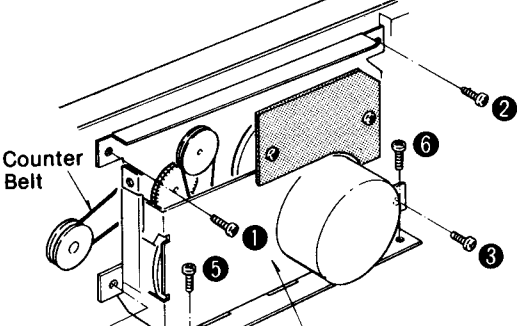
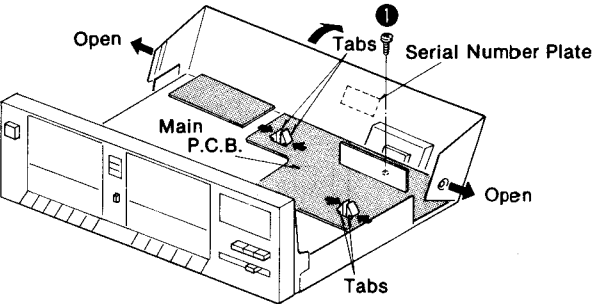
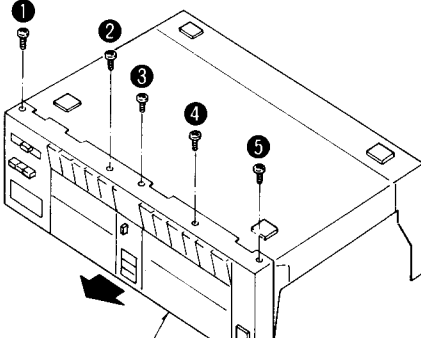
<p>Ref. No. 1</p>	<p><b>How to remove the cabinet</b></p>	<p>Ref. No. 3</p>	<p><b>How to remove the LED meter P.C.B. and VR/SW P.C.B.</b></p>
<p>Procedure 1</p>	<p>• Remove the 4 screws (①~④).</p>	<p>Procedure 1→3</p>	<p>1. Remove the one screw (①). 2. Push the 3 tabs aside, and then remove the LED P.C.B. 3. Remove the 2 screws (②, ③). 4. Push the 3 tabs aside, and then remove the VR/SW P.C.B.</p>
 <p style="text-align: center;">Fig. 1</p>		 <p style="text-align: center;">Fig. 3</p>	
<p>Ref. No. 2</p>	<p><b>How to remove the mechanism unit</b></p>	<p>Ref. No. 5</p>	
<p>Procedure 1→2</p>	<p>1. Push the eject button (see fig. 1). 2. Remove the 6 screws (①~⑥). 3. Remove the counter belt (for mechanism unit of tape ②).</p>	<p>Procedure 1→5</p>	
 <p style="text-align: center;">Fig. 2</p>		<p><b>How to remove the main P.C.B.</b></p> <p>1. Remove the one screw (①). 2. Open the side of back chassis, and then pull down the back chassis. 3. Push the 4 tabs aside.</p>  <p style="text-align: center;">Fig. 5</p>	
<p>Ref. No. 4</p>	<p><b>How to remove the front panel</b></p>	<p>* <b>Serial No. Indication</b></p> <p>• The serial number plate of the product is attached to the back chassis (shown in fig. 5).</p>	
<p>Procedure 1→2→ 3→4</p>	<p>• Remove the 5 screws (①~⑤).</p>	<p style="text-align: center;">— 7 —</p>	
 <p style="text-align: center;">Fig. 4</p>			

\* **Serial No. Indication**

• The serial number plate of the product is attached to the back chassis (shown in fig. 5).

# ■ INFORMATION ON POWER SUPPLY JIG

## • LOCATION

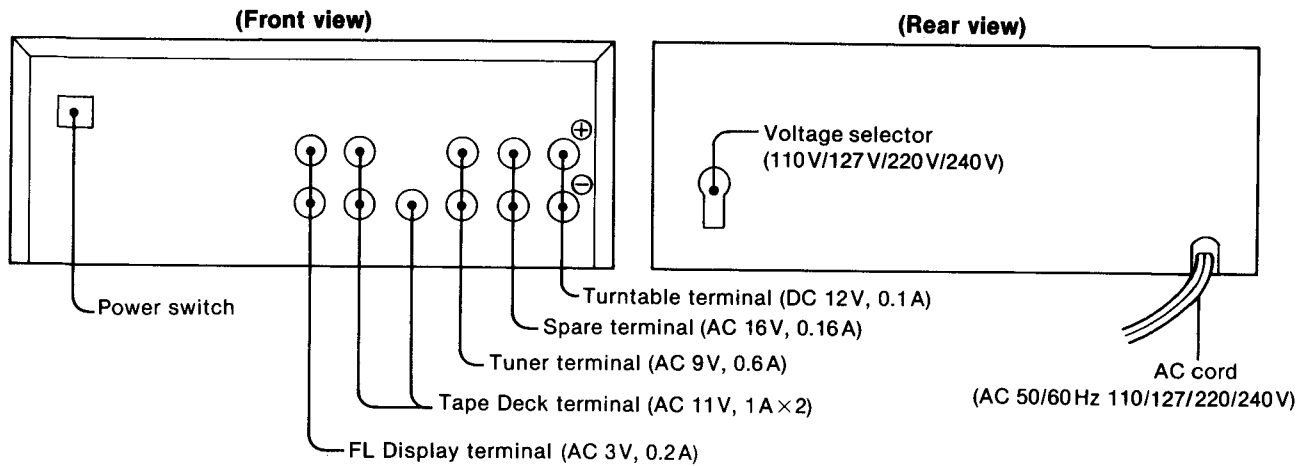

## • SCHEMATIC DIAGRAM (Reference)

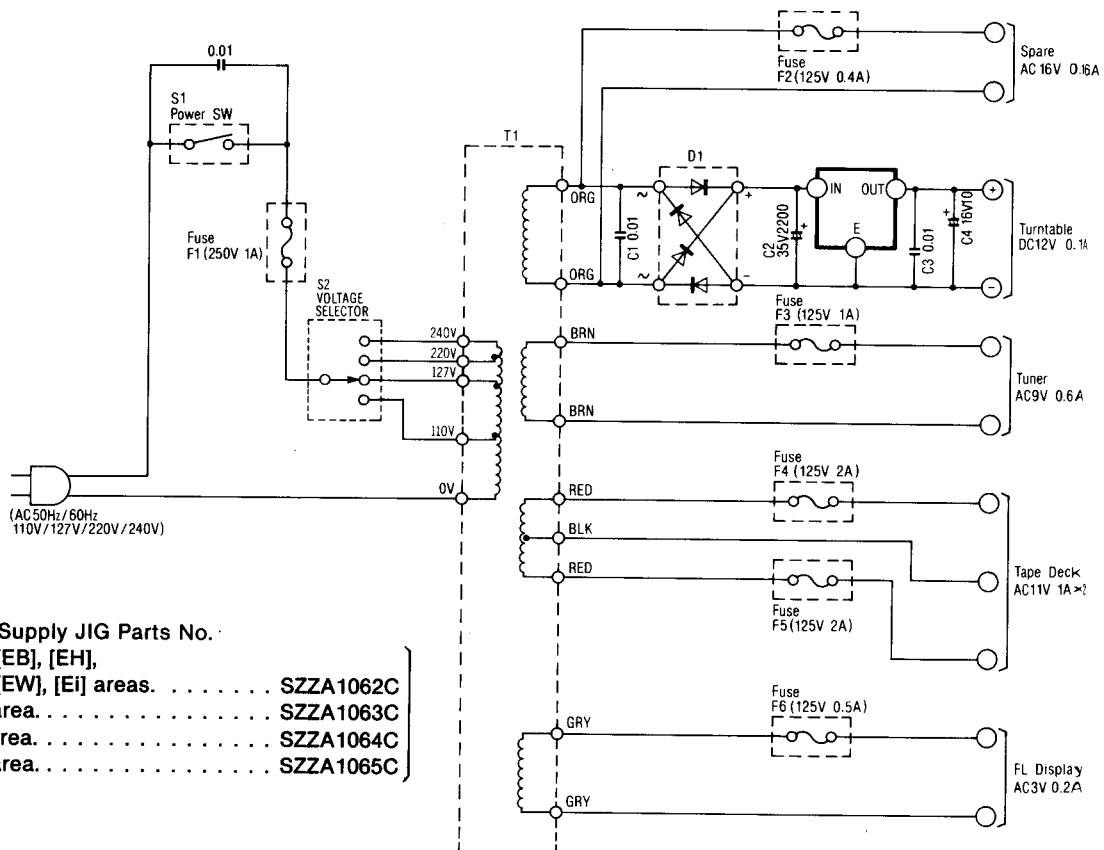

- ※ Power Supply JIG Parts No.
- [EX], [EB], [EH], [EF], [EW], [EI] areas. . . . . SZZA1062C
  - [EK] area. . . . . SZZA1063C
  - [XL] area. . . . . SZZA1064C
  - [XA] area. . . . . SZZA1065C

## • HOW TO CONNECT

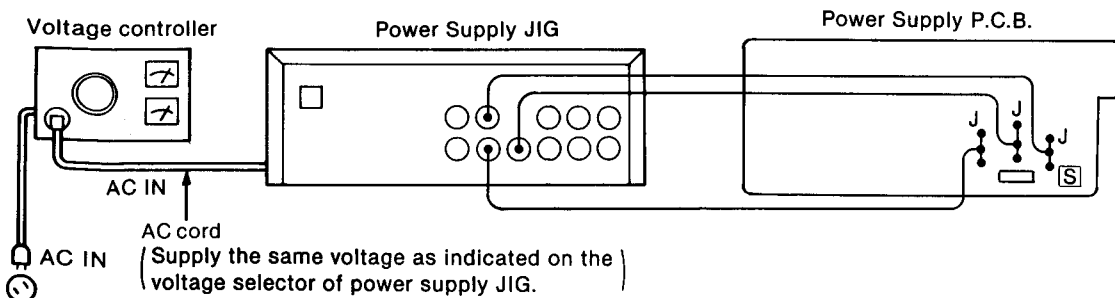

Terminal No.	
1.	
2.	
3.	
4.	
5.	
6.	
7.	
8.	
9.	
10.	
11.	
12.	

■ MEASUREMENT AND ADJUSTMENT METHODS

• Adjustment point

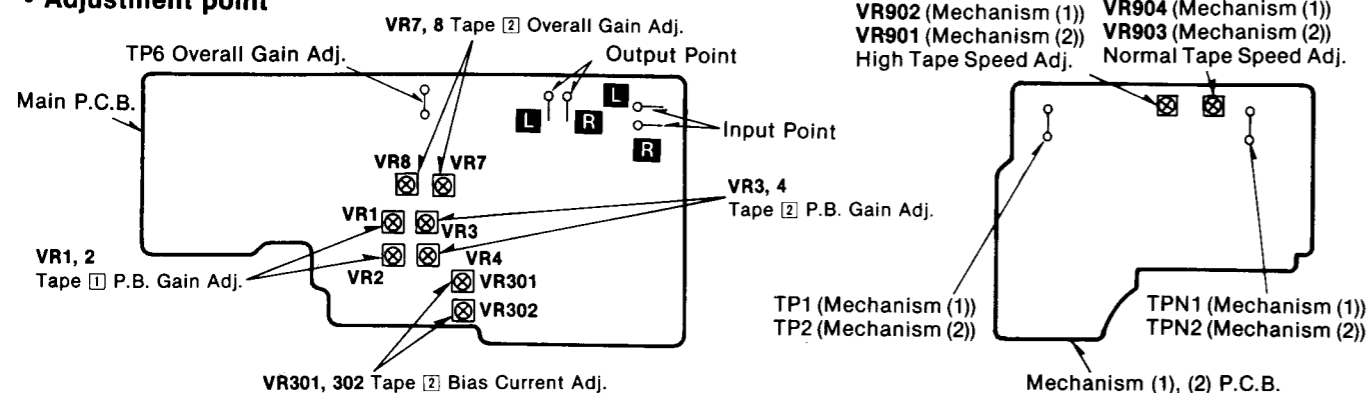

Measurement Condition

- Input level controls; Maximum
- Dolby NR switch; Off
- Editing switch; off
- Editing tape speed switch; ×1

Measuring instrument

- EVM (Electronic Voltmeter)
- Oscilloscope
- Digital frequency counter
- AF oscillator

Test tape

- Head azimuth adjustment (8kHz, -20dB); QZZCFM
- Tape speed adjustment (3kHz, -10dB); QZZCWAT
- Playback frequency response (315Hz, 12.5kHz, 10kHz, 8kHz, 4kHz, 1kHz, 250Hz, 125Hz, 63Hz, -20dB); QZZCFM
- Make sure heads are clean
- Make sure capstan and pressure roller are clean.
- Judgeable room temperature 20 ± 5°C (68 ± 9°F)
- Playback gain adjustment (315Hz, 0dB); QZZCFM
- Overall frequency response, Overall gain adjustment
  - Normal reference blank tape; QZZCRA
  - CrO<sub>2</sub> reference blank tape; QZZCRX
  - Metal reference blank tape; QZZCRZ

Head azimuth adjustment (TAPE [1], [2])

1. Test equipment connection is shown in Fig. 1.
2. Playback the azimuth adjusted part (8kHz, -20dB) of the test tape (QZZCFM) and regulate the angle adjusting screw so that the outputs of L-CH and R-CH are maximized. (When the adjusting positions are different with L-CH and R-CH, find a position where the outputs of L-CH and R-CH are balanced, and then make the adjustment.)
3. At the same time, draw a lissajous waveform and eliminate phase deflection.
4. After adjustment, lock the tape guide height and angle adjustment screws.

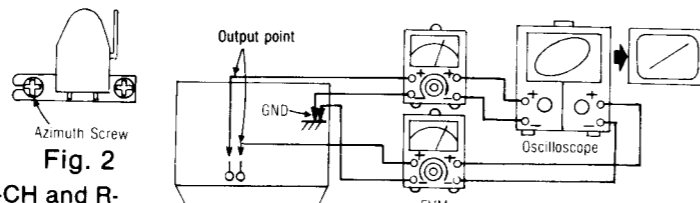

Tape speed adjustment (TAPE [1], [2])

Normal speed

1. Test equipment connection is shown in Fig. 3.
2. Playback the middle part of the test tape (QZZCWAT).
3. Adjust TAPE [1]: VR904 and TAPE [2]: VR903 so that the output is within the standard.

High speed

4. Set the editing speed switch to "×2" and short the TAPE [1]: TP1 and TPN1 and TAPE [2]: TP2 and TPN2.
5. Playback the middle part of the test tape (QZZCWAT).
6. Adjust TAPE [1]: VR902 and TAPE [2]: VR901 so that the output is within the standard.

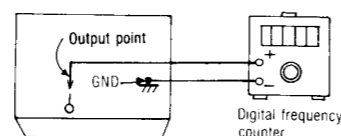

Standard value: 3000 ± 20 Hz (Normal) 6000 ± 40 Hz (High)

Playback frequency response (TAPE [1], [2])

1. Test equipment connection is shown in Fig. 4.
2. Playback the playback frequency response part (315Hz, 12.5kHz~63Hz, -20dB) of the test tape (QZZCFM).
3. Check that the frequency is within the range shown in Fig. 5 for both L-CH and R-CH.

Fig. 4

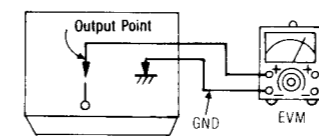
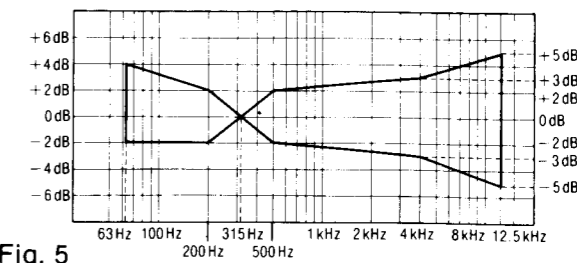

Fig. 5



Playback gain adjustment (TAPE [1], [2])

1. Test equipment connection is shown in Fig. 4.
2. Playback the playback gain adjusted part (315Hz, 0dB) of the test tape (QZZCFM).
3. Adjust TAPE [1]: VR1 (L-CH) {VR2 (R-CH)} and TAPE [2]: VR3 (L-CH) {VR4 (R-CH)} so that the output is within the standard.

Standard value: 0.4 ± 0.5 dB (0.02V)

Overall frequency response (TAPE [2])

1. Test equipment connection is shown in Fig. 6, and connect a jumper of TP6. (See page 9).
2. Set a normal blank tape (QZZCRA) and record by applying signal (50Hz, 100Hz, 200Hz, 500Hz, 1kHz, 4kHz, 8kHz and 10kHz), 20dB attenuated from the reference input level signal (1kHz, -24dB).
3. Playback the signal recorded in step 2, and check that the level of each output frequency is within the range shown in Fig. 7 in comparison with the reference frequency (1kHz).
4. If it is not within the standard range, adjust the bias current by VR301 (L-CH) {VR302 (R-CH)} so that the frequency level is within the standard.
  - Level up in high frequency range..... Increase the bias current.
  - Level down in high frequency range..... Decrease the bias current.
5. After that increase the signal recorded on CrO<sub>2</sub> blank tape (QZZCRX) and metal blank tape (QZZCRZ) up to 12.5kHz and adjust in the same way as mentioned above and check that the frequency level is within the range shown in Fig. 8.
6. After adjustment, cut a jumper of TP6.

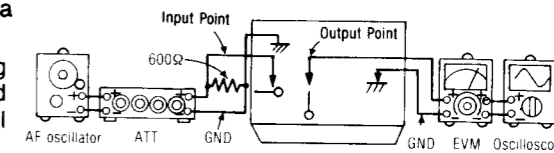

Fig. 6

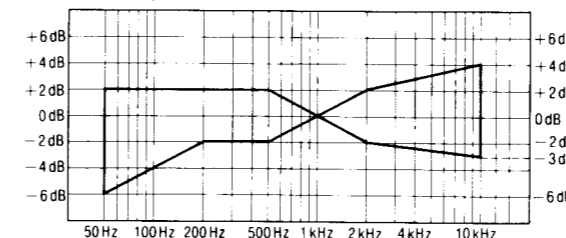

Fig. 7

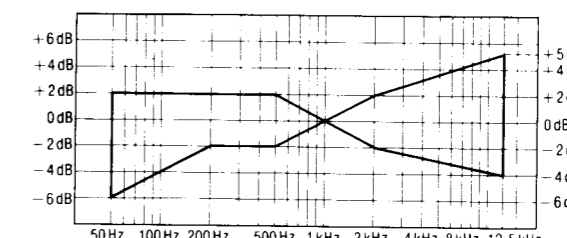

Fig. 8

Overall gain adjustment (TAPE [2])

1. Test equipment connection is shown in Fig. 6, and connect a jumper of TP6. (See page 9).
2. Set a normal blank tape (QZZCRA) and apply the reference input level signal (1kHz, -24dB) in record pause mode.
3. Adjust the output 0.4V by attenuator and then record.
4. Playback the signal recorded in step 3, and check that the output is within the standard.
5. If it is not within the standard, adjust VR7 (L-CH) {VR8 (R-CH)} and repeat the step (2), (3) and (4) until the output is within the standard.
6. After adjustment, cut a jumper of TP6.

Standard value: 0.4V ± 0.1V - 0.08V

Dolby NR circuit

1. Test equipment connection is shown in Fig. 9.
2. Set a normal tape and apply 5kHz signal in record pause mode.
3. Adjust by attenuator so that the output between terminal ⑥ (L-CH) {terminal ⑩ (R-CH)} of IC401 and ground is 12.3mV.
4. Turn NR switch ON, and check that the level changes as specified from the level in NR out mode.

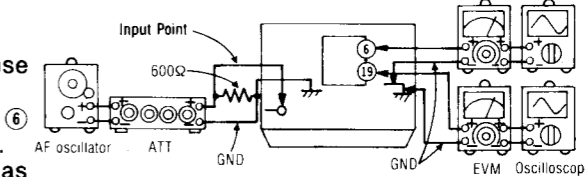
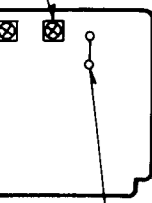

Fig. 9

Standard value: 8 ± 1.5dB

4 (Mechanism (1))  
3 (Mechanism (2))  
al Tape Speed Adj.



PN1 (Mechanism (1))  
PN2 (Mechanism (2))

1), (2) P.C.B.

er are clean.  
C (68 ± 9 °F)

B); QZZCFM  
gain adjustment  
RA

Z

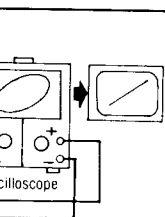

3

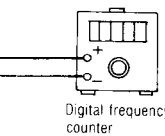

3

### Playback frequency response (TAPE 1, 2)

1. Test equipment connection is shown in Fig. 4.
2. Playback the playback frequency response part (315Hz, 12.5kHz~63Hz, -20dB) of the test tape (QZZCFM).
3. Check that the frequency is within the range shown in Fig. 5 for both L-CH and R-CH.

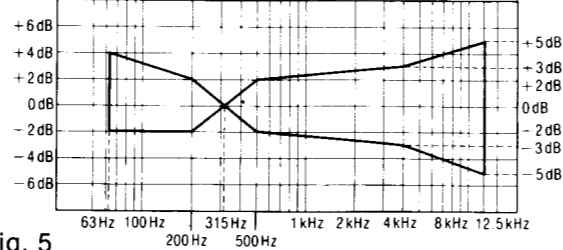
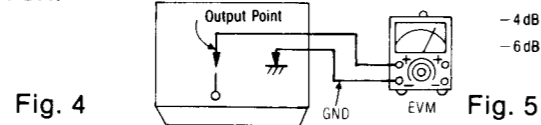

### Playback gain adjustment (TAPE 1, 2)

1. Test equipment connection is shown in Fig. 4.
2. Playback the playback gain adjusted part (315Hz, 0dB) of the test tape (QZZCFM).
3. Adjust TAPE 1: VR1 (L-CH) {VR2 (R-CH)} and TAPE 2: VR3 (L-CH) {VR4 (R-CH)} so that the output is within the standard.

Standard value:  $0.4 \pm 0.5 \text{ dB (0.02V)}$

### Overall frequency response (TAPE 2)

1. Test equipment connection is shown in Fig. 6, and connect a jumper of TP6. (See page 9).
2. Set a normal blank tape (QZZCRA) and record by applying signal (50Hz, 100Hz, 200Hz, 500Hz, 1kHz, 4kHz, 8kHz and 10kHz), 20dB attenuated from the reference input level signal (1kHz, -24dB).
3. Playback the signal recorded in step 2, and check that the level of each output frequency is within the range shown in Fig. 7 in comparison with the reference frequency (1kHz).
4. If it is not within the standard range, adjust the bias current by VR301 (L-CH) {VR302 (R-CH)} so that the frequency level is within the standard.
  - Level up in high frequency range..... Increase the bias current.
  - Level down in high frequency range..... Decrease the bias current.
5. After that increase the signal recorded on CrO<sub>2</sub> blank tape (QZZCRX) and metal blank tape (QZZCRZ) up to 12.5kHz and adjust in the same way as mentioned above and check that the frequency level is within the range shown in Fig. 8.
6. After adjustment, cut a jumper of TP6.

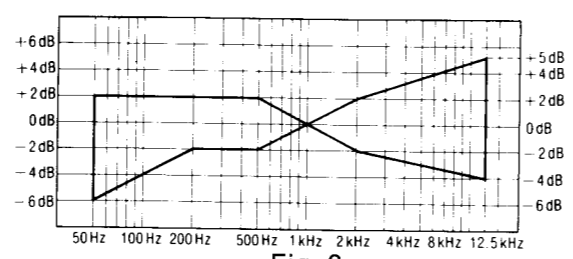
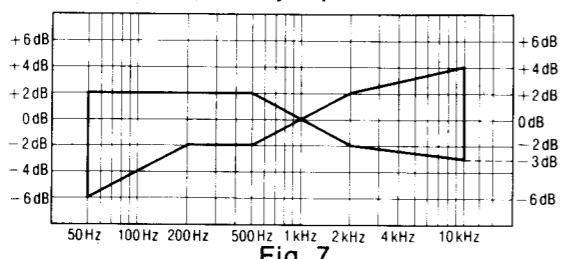
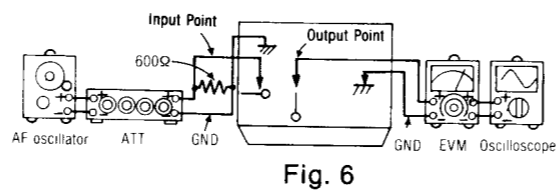

### Overall gain adjustment (TAPE 2)

1. Test equipment connection is shown in Fig. 6, and connect a jumper of TP6. (See page 9).
2. Set a normal blank tape (QZZCRA) and apply the reference input level signal (1kHz, -24dB) in record pause mode.
3. Adjust the output 0.4V by attenuator and then record.
4. Playback the signal recorded in step 3, and check that the output is within the standard.
5. If it is not within the standard, adjust VR7 (L-CH) {VR8 (R-CH)} and repeat the step (2), (3) and (4) until the output is within the standard.
6. After adjustment, cut a jumper of TP6.

Standard value:  $0.4V + 0.1V - 0.08V$

### Dolby NR circuit

1. Test equipment connection is shown in Fig 9.
2. Set a normal tape and apply 5kHz signal in record pause mode.
3. Adjust by attenuator so that the output between terminal ⑥ (L-CH) {terminal ⑨ (R-CH)} of IC401 and ground is 12.3mV.
4. Turn NR switch ON, and check that the level changes as specified from the level in NR out mode.

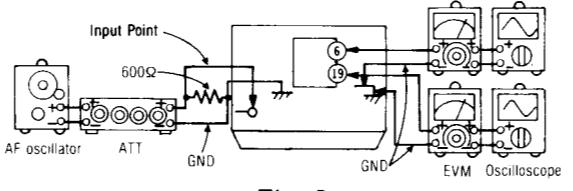

Standard value:  $8 \pm 1.5 \text{ dB}$

## ■ MICROCOMPUTER TERMINAL FUNCTION AND WAVEFORM

### (IC801: MN1402STN)

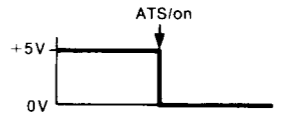
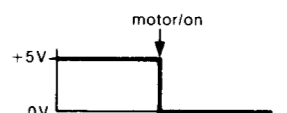
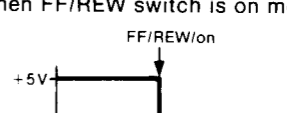
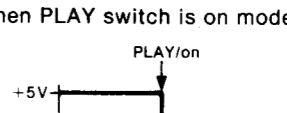
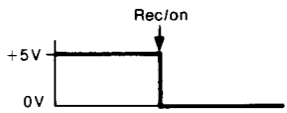
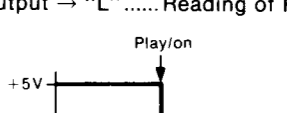
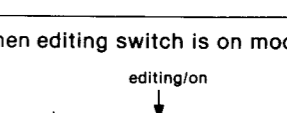
Terminal No.	Symbol	Name	Function/operation
1.	Vss	—	• Connection to GND.
2.	CO9	P.B. mute	• "H" in mute on, "L" in mute off.
3.	CO8	Auto tape selector	• "H" in 70μS mode, "L" in 120μS mode.
4.	CO7	Bias	• "H" in bias off, "L" in bias on.
5.	CO6	Direct muting	• "H" in mute off, "L" in mute on.
6.	CO5	—	• Non connection.
7.	AI3	Reading of input switch state tape ① auto tape selector (S909)	• "L" when auto tape selector is on mode. 
8.	AI2	Reading of input switch state tape ① motor (S904)	• "L" when motor switch is on mode. 
9.	AI1	Reading of input switch state tape ① FF/REW (S906)	• "L" when FF/REW switch is on mode. 
10.	AIφ	Reading of input switch state tape ① PLAY (S902)	• "L" when PLAY switch is on mode. 
11.	BI3	Reading of scan signal output	• Input of Tape 2 REC switch, Tape 2 PLAY switch. • The above-mentioned inputs are read in accordance with DOφ scanning. DOφ output → "L"..... Reading of REC switch.  DO1 output → "L"..... Reading of PLAY switch. 
12.	BI2	Reading of input switch state editing (S802)	• "H" when editing switch is on mode. 

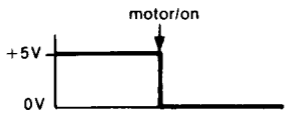
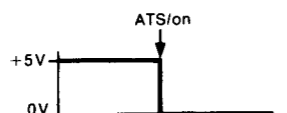
Terminal No.	Symbol	Name	Function/operation
13.	B11	Reading of input switch state tape 2 motor (S903)	<ul style="list-style-type: none"> <li>• "L" when motor switch is on mode.</li> </ul> 
14.	B1φ	Reading of input switch state tape 2 auto tape selector (S907)	<ul style="list-style-type: none"> <li>• "L" when auto tape selector is on mode.</li> </ul> 
15.	EOφ	Head selector	• "H" in tape 1 Head, "L" in tape 2 Head.
16.	EO1	Tape speed selector	• "H" in high speed, "L" in normal speed.
17.	EO2	Dolby NR IN/OUT	• "H" in REC mode, "L" in PLAY mode.
18.	EO3	Dolby B/C NR selector	• "H" in PLAY mode, "L" in REC mode.
19.	RST	Reset terminal	<ul style="list-style-type: none"> <li>• Used to reset the microcomputer when power is thrown in.</li> <li>• Reset at "L".</li> </ul>
20.	TEST	—	• Connection to GND.
21.	DO3	Motor 2	• "H" in motor 2 off, "L" in motor 2 on.
22.	DO2	Motor 1	• "H" in motor 1 off, "L" in motor 1 on.
23.	DO1	SCAN 2	• Scan signal for reading of tape 2 PLAY switch input.
24.	DOφ	SCAN 1	• Scan signal for reading of REC switch input.
25.	SNSφ	Remote control signal input	• Input of serial signal from remote control jack.
26.	SNS1	Reading of input switch state tape speed (S802)	• "H" when tape speed switch is ×2 mode.

• Terminal Guide of Transistors, Diodes and IC's

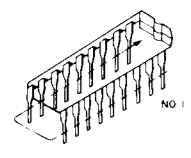
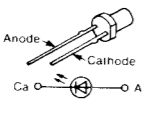
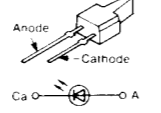
	μPC1290C 14 Pin AN6888 18 Pin NE657N 24 Pin MN1402STN 28 Pin AN7014K 30 Pin	M5218L 8 Pin MN6634 9 Pin	2SB621ARS 2SD592AQRS	2SA1309AQS 2SB1030QRS 2SC3311AQS 2SD1423QRS 2SD1450R UN4113 UN4114 UN4116, UN4213
	1SS254 1SR35200	MA4160M MA4062M	 LN463YCPP (YEL) LN863RCPP (RED)	 LN846RP (RED) LN346GP (GRN) LN446YP (YEL)

■ WIRING CONNECTION DIAGRAM

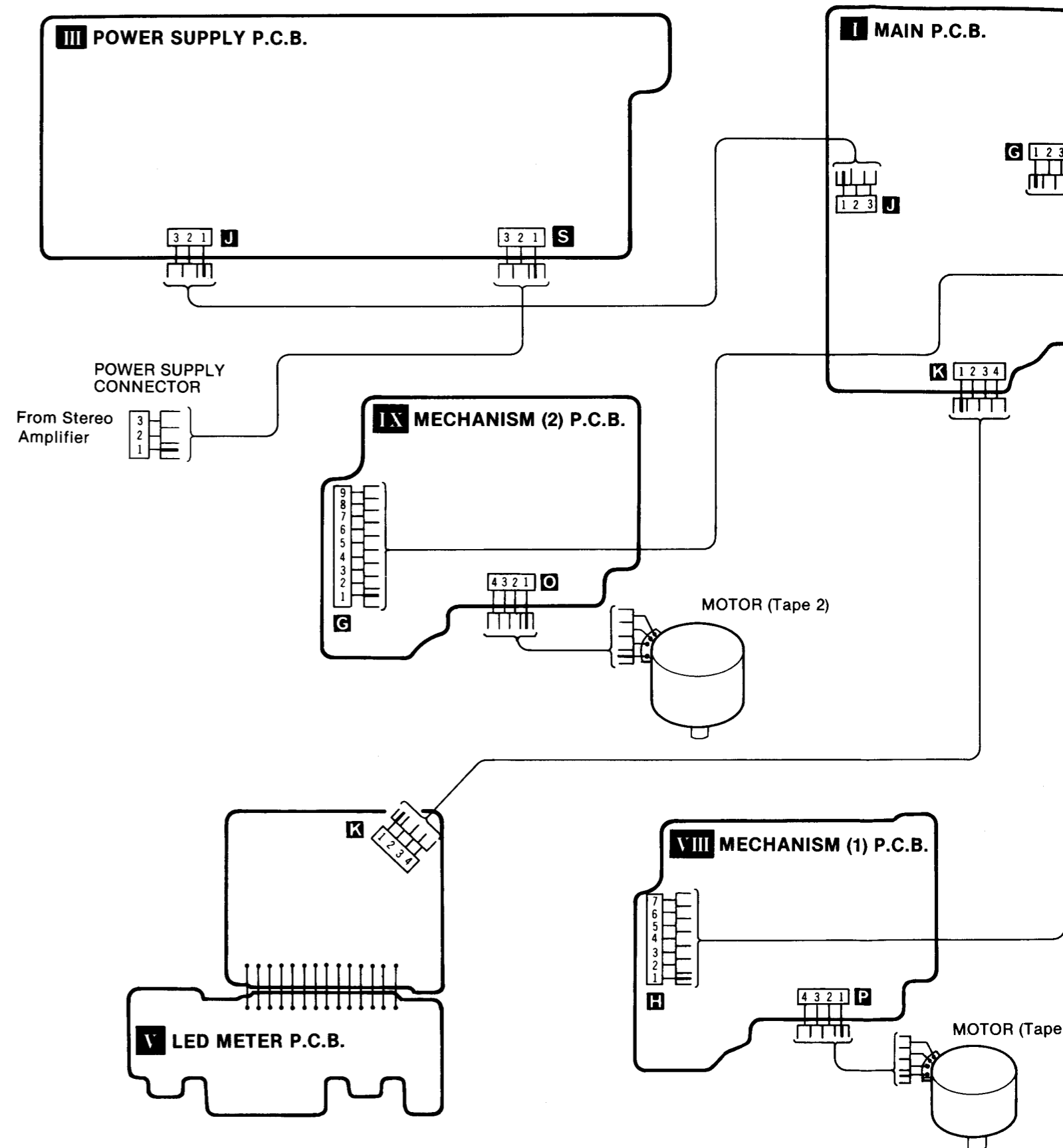

# WIRING CONNECTION DIAGRAM

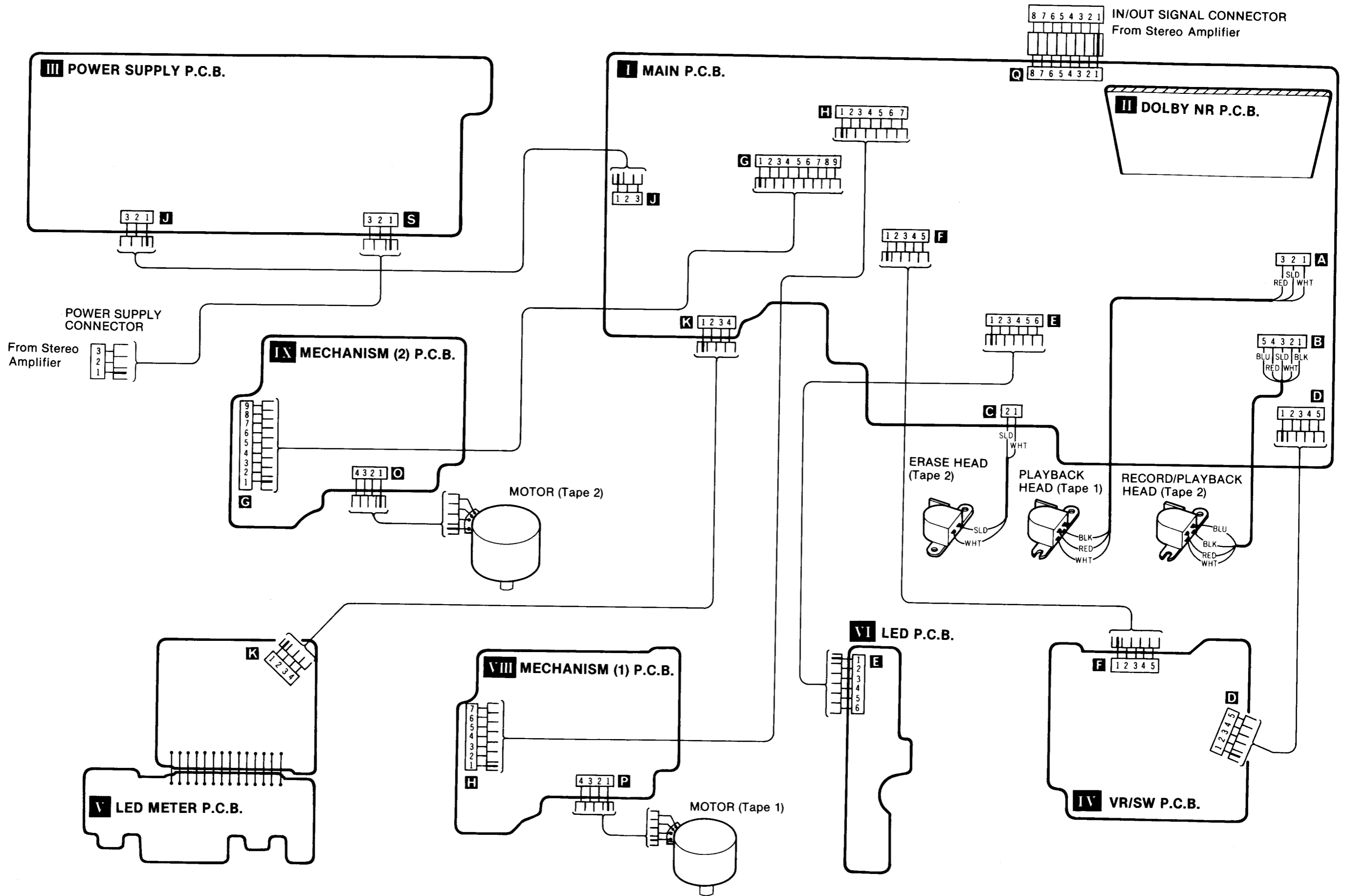

- 309AQS
  - 030QRS
  - 011AQS
  - 423QRS
  - 450R
  - 13
  - 14
  - 16, UN4213
- 
- SRP (RED)
  - SGP (GRN)
  - SY (YEL)



1 2 3 4 5 6 7 8 9 10

**PRINTED CIRCUIT BOARDS**

**VIII MECHANISM (1) P.C.B.**

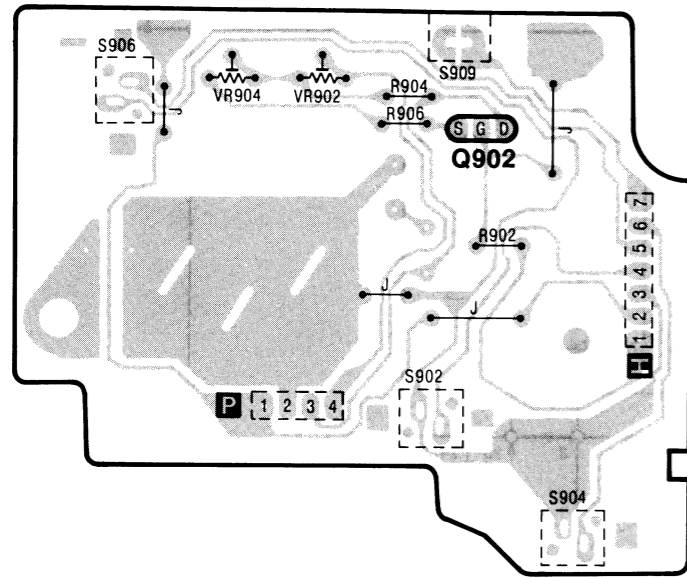

**IX MECHANISM (2) P.C.B.**

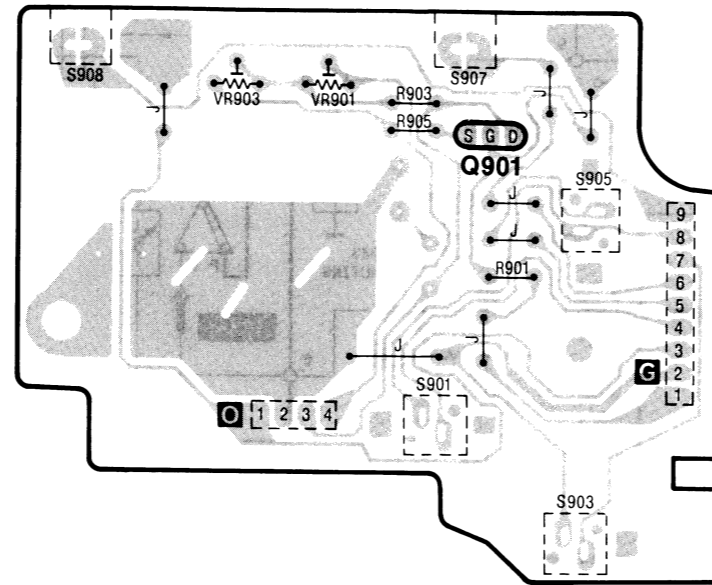

**V LED METER P.C.B.**

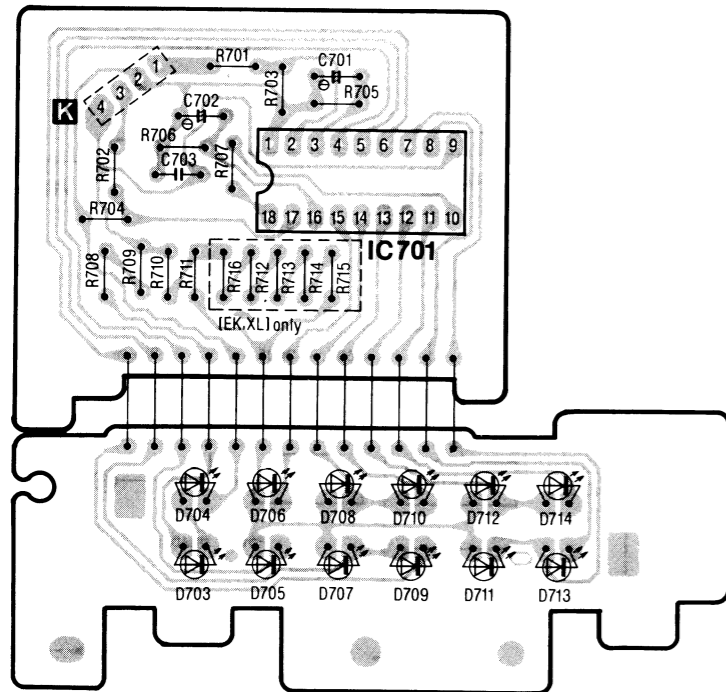

**VI LED P.C.B.**

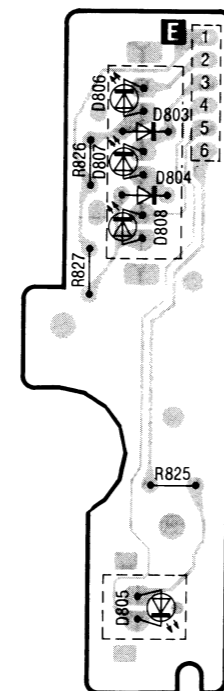

**IV VR/SW P.C.B.**

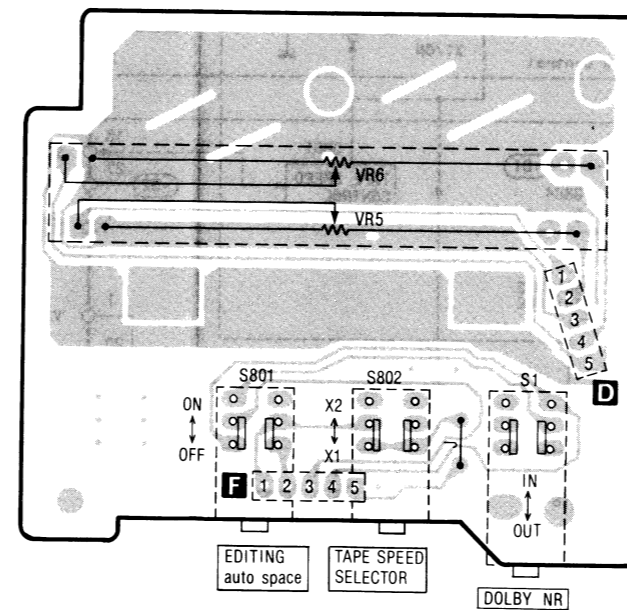

**I MAIN P.C.B.**

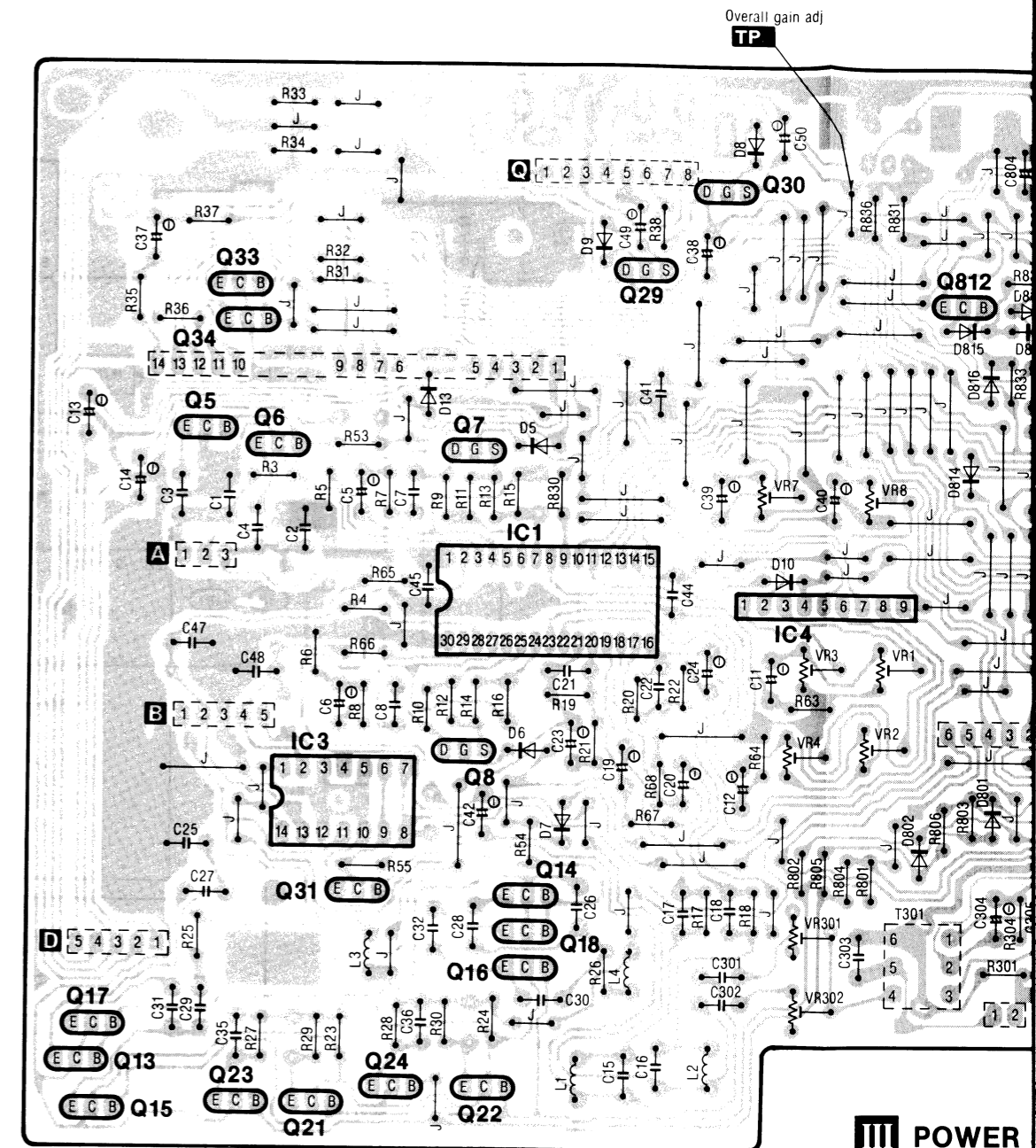

**III POWER**

**II DOLBY NR P.C.B.**

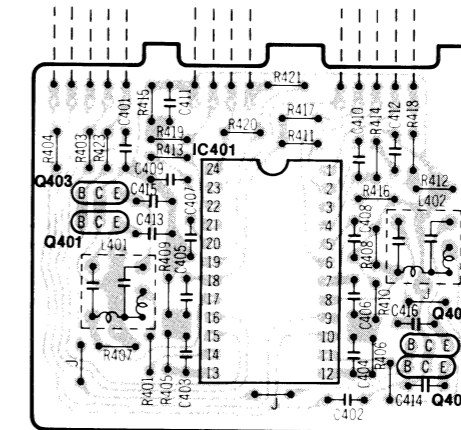

**I MAIN P.C.B.**

**MECHANISM (2) P.C.B.**

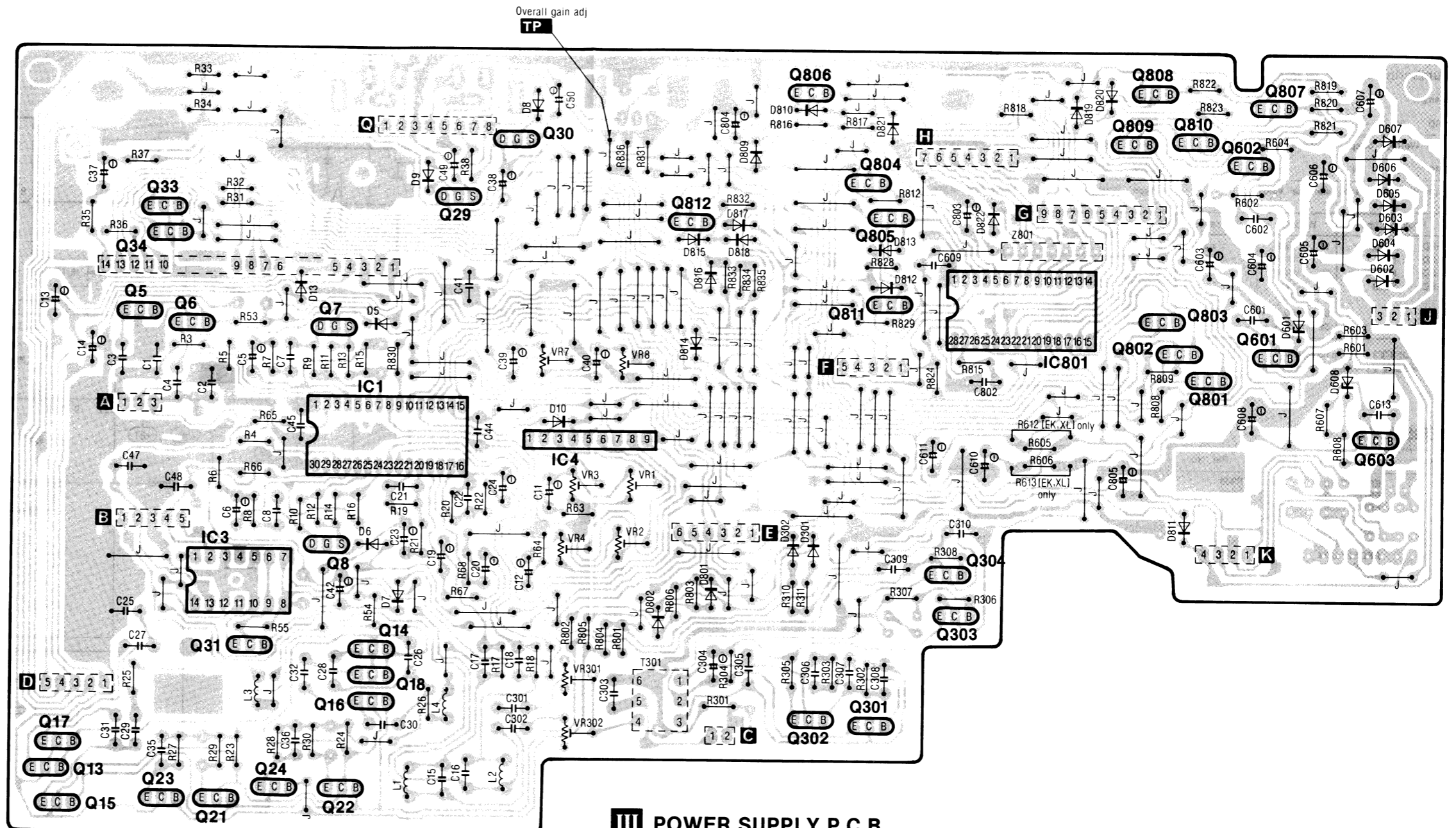
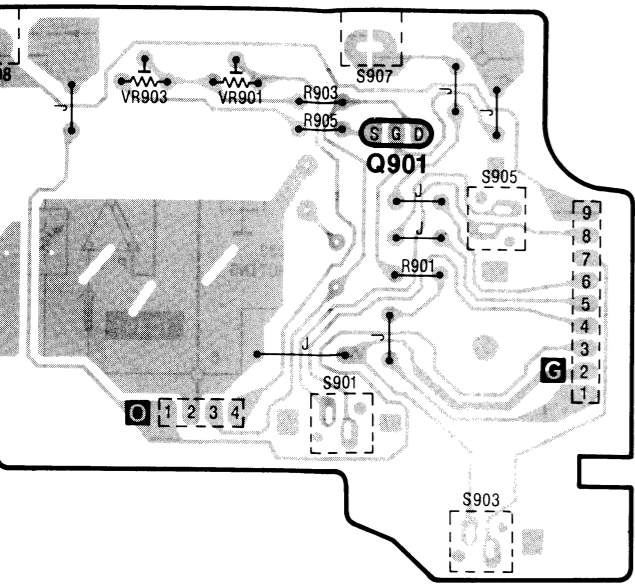

**C.B.**

**IV VR/SW P.C.B.**

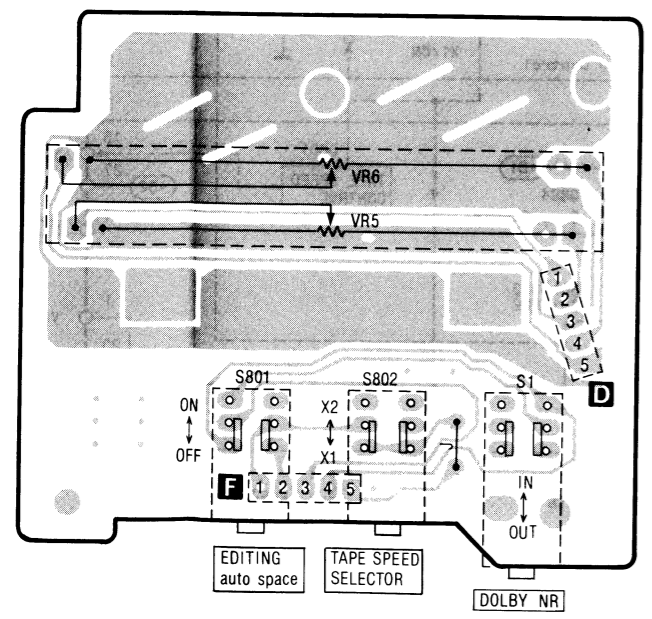

**II DOLBY NR P.C.B.**

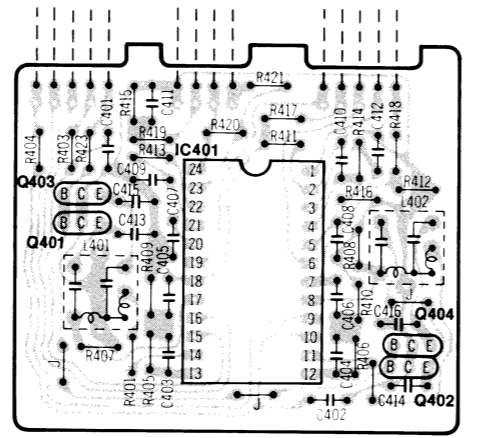

# RESISTORS AND CAPACITORS

- Notes:**
- Part numbers are indicated on most mechanical parts. Please use this part number for parts order.
  - The unit of resistance is  $\Omega$  (ohm). K=1000 $\Omega$ , M=1000k $\Omega$

- The unit of capacitance is  $\mu\text{F}$  (microfarad). P=10<sup>-6</sup> $\mu\text{F}$ .
- Bracketed indications in Ref. columns specify the area. Parts without these indications can be used for all area.

## Numbering System of Resistor

**Example**

ERD	25	F	J	101
Type	Wattage	Shape	Tolerance	Value
ERG	2	AN	J	2R2
Type	Wattage	Shape	Tolerance	Value

## Numbering System of Capacitor

**Example**

ECKD	1H	102	Z	F
Type	Voltage	Value	Tolerance	Pecularity
ECEA	50	M	R47	R
Type	Voltage	Pecularity	Value	Special use

Resistor Type	Wattage	Tolerance
ERD : Carbon	10 : 1/8W	G : $\pm 2\%$
ERO : Film	12 : 1/2W	J : $\pm 5\%$
ERG : Metal Oxide	25 : 1/4W	
ERC : Solid	1 : 1W	
	2 : 2W	
	S1 : 1/2W	
	S2 : 1/4W	

Capacitor Type	Voltage		Tolerance
	ECEA Type	Other	
ECEA : Electrolytic	0J : 6.3V	1H : 50V	CJ : $\pm 0.25\mu\text{F}$
ECCD : Ceramic	1A : 10V	2H : 500V	J : $\pm 5\%$
ECKD : Ceramic	1C : 16V	1 : 100V	K : $\pm 10\%$
ECQM : Polyester	1E : 25V	KC : 400V	Z : $\pm 80\%, -20\%$
ECQP : Polyester	1H : 50V		Y : $\pm 22\%$
ECET : Electrolytic	1J : 63V		
ECEA...N : Non-polar Electrolytic	1V : 35V		
	25 : 25V		
	56 : 56V		

ERD10TLJ□□□ → Chip type carbon  
ERO10MKG□□□ → Chip type metal film

## RESISTORS

Ref. No.	Part No.	Value	Ref. No.	Part No.	Value	Ref. No.	Part No.	Value	Ref. No.	Part No.	Value
R3, 4	ERDS2TJ101	100	R308	ERDS2TJ561	560	R607	ERDS2TJ102	1K	R804	ERDS2TJ563	56K
R5, 6	ERDS2TJ820	82	R310	ERDS2TJ331	330	R608 [EK, XL]	ERDS2TJ101	100	R805, 806	ERDS2TJ103	10K
R7, 8	ERDS2TJ392	3.9K	R311	ERDS2TJ220	22	R608 [other]	ERDS2TJ560	56	R808	ERDS2TJ332	3.3K
R9, 10	ERDS2TJ272	2.7K	R401, 402	ERDS2TJ242	2.4K	R610, 611	ERQ14LKR22	0.22	R809	ERDS2TJ392	3.9K
R11, 12	ERDS2TJ122	1.2K	R403, 404	ERDS2TJ471	470	R612, 613	ERG1ANJ560	56	R812	ERDS2TJ473	47K
R13, 14	ERDS2TJ332	3.3K	R405, 406	ERDS2TJ473	47K	[EK, XL] only			R815	ERDS2TJ183	18K
R15, 16	ERDS2TJ274	270K	R407, 408	ERDS2TJ432	4.3K	[EK, XL] only			R816	ERDS2TJ103	10K
R17, 18	ERDS2TJ103	10K	R409, 410	ERDS2TJ332	3.3K	R701, 702	ERDS2TJ363	36K	R817	ERDS2TJ123	12K
R19, 20	ERDS2TJ153	15K	R411, 412	ERDS2TJ102	1K	R703, 704	ERDS2TJ472	4.7K	R818, 819	ERDS2TJ102	1K
R21, 22	ERDS2TJ472	4.7K	R413, 414	ERDS2TJ274	270K	R705, 706	ERDS2TJ154	150K	R820	ERDS2TJ473	47K
R23, 24	ERDS2TJ102	1K	R415, 416	ERDS2TJ184	180K	R707	ERDS2TJ562	5.6K	R821	ERDS2TJ152	1.5K
R25, 26	ERDS2TJ330	33	R417, 418	ERDS2TJ470	47	R708, 709	ERDS2TJ221	220	R822	ERDS2TJ473	47K
R27, 28	ERDS2TJ182	1.8K	R419	ERDS2TJ512	5.1K	R710 [EK, XL]	ERDS2TJ6R8	6.8	R823	ERDS2TJ152	1.5K
R29, 30	ERDS2TJ472	4.7K	R420	ERDS2TJ103	10K	R710 [other]	ERDS2TJ330	33	R824	ERDS2TJ223	22K
R31, 32	ERDS2TJ103	10K	R421	ERDS2TJ102	1K	R711 [EK, XL]	ERDS2TJ471	470	R825	ERDS2TJ102	1K
R33, 34	ERDS2TJ273	27K	R423	ERDS2TJ102	1K	R711 [other]	ERDS2TJ330	33	R826, 827	ERDS2TJ391	390
R35, 36	ERDS2TJ152	1.5K	R601, 602	ERD2FCG100	10	R712, 713	ERDS2TJ150	15	R828, 829	ERDS2TJ103	10K
R37, 38	ERDS2TJ274	270K	[EK, XL]	ERDS2TJ100	10	R714, 715	ERDS2TJ150	15	R830, 831	ERDS2TJ102	1K
R53, 54	ERDS2TJ103	10K	R601, 602	ERD2FCG100	10	R716	ERDS2TJ150	15	R832	ERDS2TJ472	4.7K
R55	ERDS2TJ223	22K	[EK, XL]	ERDS2TJ100	10	[EK, XL] only			R833	ERDS2TJ103	10K
R63, 64	ERDS2TJ103	10K	R603, 604	ERDS2TJ102	1K	R716	ERDS2TJ150	15	R834, 835	ERDS2TJ472	4.7K
R65, 66	ERDS2TJ101	100	[EK, XL]	ERDS2TJ102	1K	R801	ERDS2TJ103	10K	R836	ERDS2TJ103	10K
R67, 68	ERDS2TJ562	5.6K	R605, 606	ERDS2TJ271	270	R802	ERDS2TJ332	3.3K	R901, 902	ERDS2TJ104	100K
R301	ERDS2TJ1R0	1	[EK, XL]	ERDS2TJ470	47	R803	ERDS2TJ272	2.7K	R903, 904	ERDS2TJ223	22K
R302, 303	ERDS2TJ683	68K							R905, 906	ERDS2TJ103	10K
R304, 305	ERDS2TJ100	10									
R306	ERDS2TJ561	560									
R307	ERDS2TJ183	18K									

## CAPACITORS

Ref. No.	Part No.	Value	Ref. No.	Part No.	Value	Ref. No.	Part No.	Value	Ref. No.	Part No.	Value
C1, 2	ECKD1H271KB	270P	C31, 32	ECFTD333KXL	0.033	C308	ECFTD222KXL	0.0022	C607	ECEA1CU102	1000
C3, 4	ECKD1H391KB	390P	C35, 36	ECFTD153KXL	0.015	C309	ECKD1H223ZF	0.022	C608	ECEA0JU222	2200
C5, 6	ECEA0JU101	100	C37, 38	ECEA1EU4R7	4.7	C310	ECKD1H473ZF	0.047	C809	ECKD1H223ZF	0.022
C7, 8	ECQB1H123JZ	0.012	C39, 40	ECEA1HU2R2	2.2	C401, 402	ECKD1H221KB	220P	C610	ECEA1AU221	220
C11, 12	ECEA1EU4R7	4.7	C41	ECKD1H473ZF	0.047	C403, 404	ECQB1H472JZ	0.0047	C611	ECEA1AU471	470
C13, 14	ECEA1HU010	1	C42	ECEA1HU2R2	2.2	C405, 406	ECQM1H333JZ	0.033	C612	ECKD2H682PEL	0.0068
C15, 16	ECKD2H101KB	100P	C44, 45	ECKD1H223ZF	0.022	C407, 408	ECQM1H473JZ	0.047	C613	ECKD1H223ZF	0.022
C17, 18	RCBS1H561KB	560P	C47, 48	ECKD1H681KB	680P	C409, 410	ECQM1H334JZ	0.33	C701, 702	ECEA1HU2R2	2.2
C19, 20	ECEA1HU010	1	C49, 50	ECEA1EU4R7	4.7	C411, 412	ECQM1H104JZ	0.1	C703	ECKD1H223ZF	0.022
C21, 22	RCBS1H181KB	180P	C301, 302	ECED1H221K	220P	C413, 414	ECKD1H122KB	0.0012	C802	ECED1H101K	100P
C23, 24	ECEA1HU010	1	C303	ECQP1H83JZ	0.018	C415, 416	ECKD1H152KB	0.0015	C803	ECEA1EU4R7	4.7
C25, 26	ECQB1H102JZ	0.001	C304	ECEA1CU470	47	C801, 802	ECKD1H223ZF	0.022	C804	ECEA1AU221	220
C27, 28	ECQB1H223JZ	0.022	C305	ECKD1H392KB	0.0039	C803, 804	ECEA1AU221	220	C805	ECEA1HUR47	0.47
C29	ECQB1H123JZ	0.012	C306	ECFTD222KXL	0.0022	C805	ECEA1CU102	1000			
C30	ECQM1H123JZ	0.012	C307	ECFTD682KXL	0.0068	C606	ECEA1CU471	470			

# BLOCK DIAGRAM

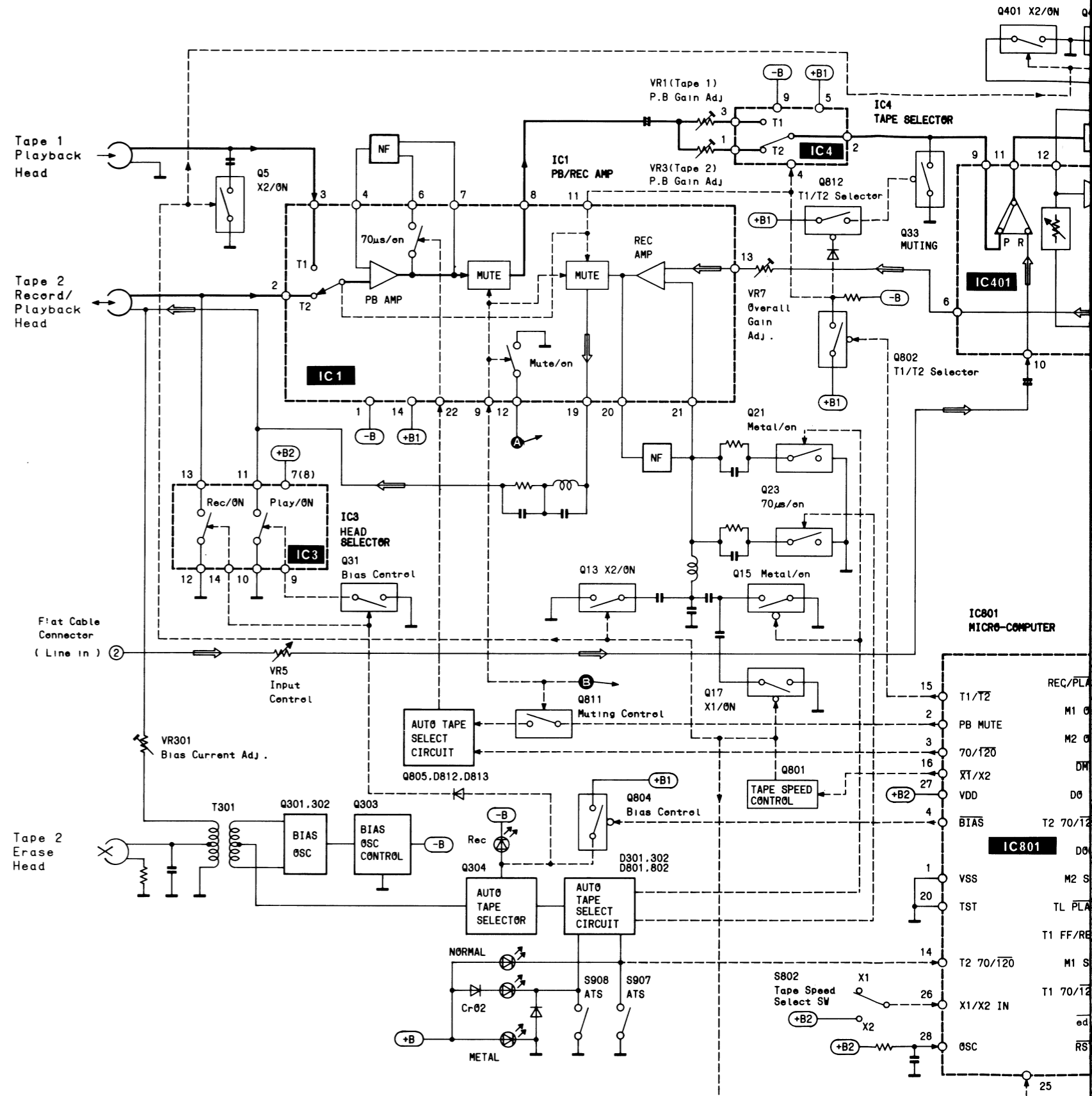

# ■ BLOCK DIAGRAM

Specify the area.  
1 for all area.

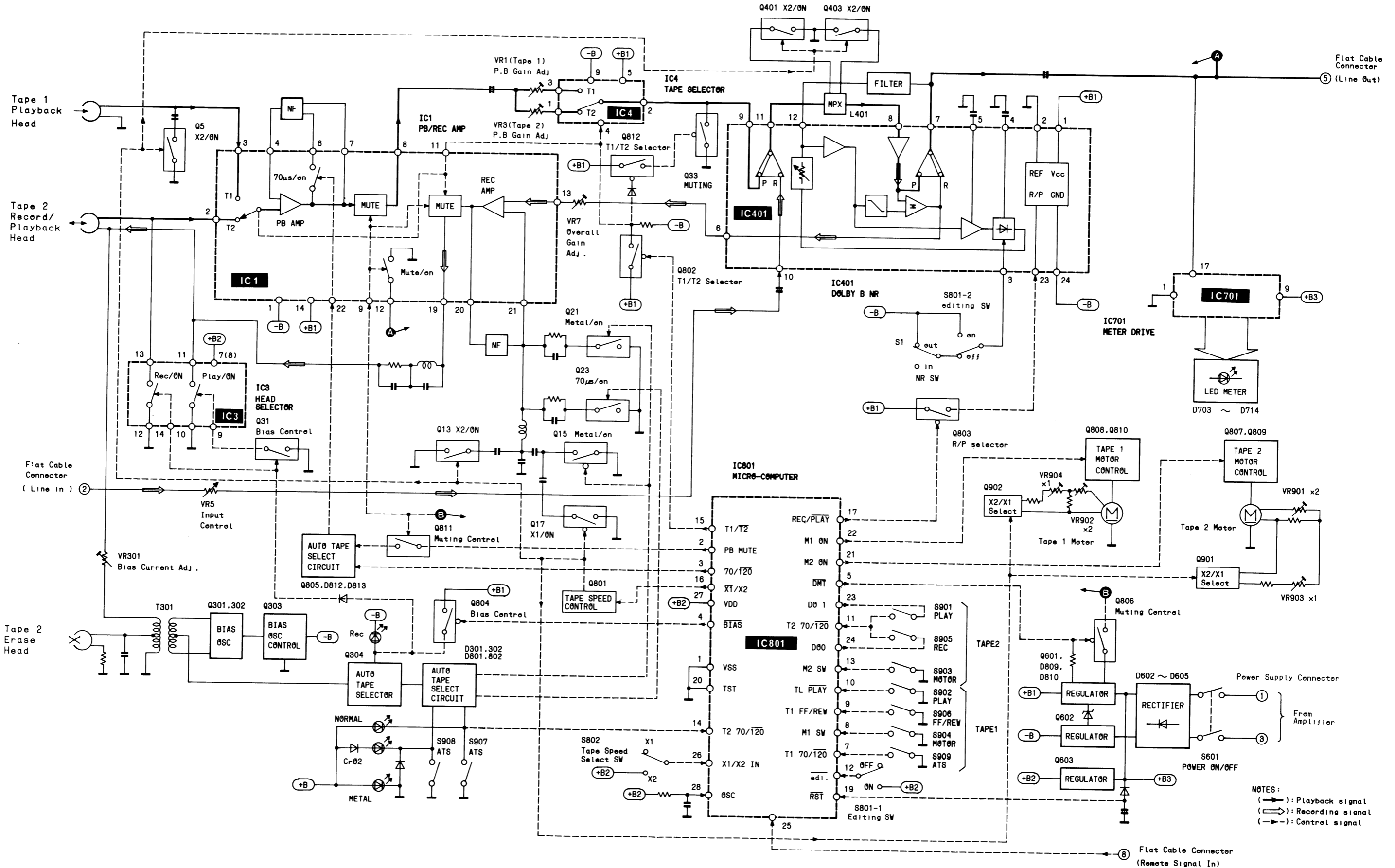

Part No.	Value
DS2TJ563	56K
DS2TJ103	10K
DS2TJ332	3.3K
DS2TJ392	3.9K
DS2TJ473	47K
DS2TJ183	18K
DS2TJ103	10K
DS2TJ123	12K
DS2TJ102	1K
DS2TJ473	47K
DS2TJ152	1.5K
DS2TJ473	47K
DS2TJ152	1.5K
DS2TJ223	22K
DS2TJ102	1K
DS2TJ391	390
DS2TJ103	10K
DS2TJ102	1K
DS2TJ472	4.7K
DS2TJ103	10K
DS2TJ472	4.7K
DS2TJ103	10K
DS2TJ104	100K
DS2TJ223	22K
DS2TJ103	10K

Part No.	Value
EA1CU102	1000
EA0JU222	2200
CD1H223ZF	0.022
EA1AU221	220
EA1AU471	470
CD2H682PEL	0.0068
CD1H223ZF	0.022
EA1HU2R2	2.2
CD1H223ZF	0.022
CD1H101K	100P
EA1EU47	4.7
EA1AU221	220
EA1HU47	0.47

NOTES:  
 (→): Playback signal  
 (⇄): Recording signal  
 (—): Control signal

## ELECTRICAL PARTS LIST

- Notes:**
- Part numbers are indicated on most mechanical parts. Please use this part number for parts order.
  - Important safety notice: Components identified by  $\Delta$  mark have special characteristics important for safety. When replacing any of these components, use only manufacturer's specified parts.

Ref. No.	Part No.	Description
<b>INTEGRATED CIRCUITS</b>		
IC1	AN7014K	IC
IC3	UPC1290C	IC
IC4	MN6634	IC
IC401	NE657	IC
IC701	AN6888	IC
IC801	MN1402STN	IC
<b>TRANSISTORS</b>		
Q5, 6, 33, 34	2SD1330R	Transistor
Q7, 8, 29, 30	2SJ40D	Transistor
Q13, 14, 21-24,	2SC3311-Q	Transistor
301, 302, 811		
Q15-18, 806	2SA1309Q	Transistor
Q31	UN4213	Transistor
Q303 [EK, XL]	2SB821A-R	Transistor
Q303 [other]	2SB1030Q	Transistor
Q304, 801, 807, 808	2SD592ANC-Q	Transistor
Q401-404	2SC3311-Q	Transistor
Q602	2SB821A-R	Transistor
Q603	2SD14230	Transistor
Q801, 802, 805, 812	UN4113	Transistor
Q803, 809, 810	UN4114	Transistor
Q804	UN4116	Transistor
Q901, 902	2SK381D	Transistor
<b>DIODES</b>		
D5, 6, 8, 9, 13, 609, 819-822	1SS254	Diode
D7, 10, 301, 302, 801-804, 809-818	MA165	Diode
D601	MA4160M	Diode
D602-607	1SR35200	Diode
D608	MA4062-M	Diode
D703-708	LN483YCPPU	L.E.D.
D709-714	LN863RCP	L.E.D.
D805, 806	LN846RP	L.E.D.
D807	LN346GP	L.E.D.
D808	LN446YP	L.E.D.
<b>COILS</b>		
L1, 2	SLQX303-1K	Choke
L3, 4	QLQX2722D	Choke
L301	SL09C19-K	Bias OSC
L401, 402	QLM9Z10K	MPX Coil
<b>VARIABLE RESISTORS</b>		
VR1-4	EVND4AA00B24	Tape 1/Tape 2 P.B. Gain Adj.
VR5, 6	EWAPB1X05A54	Input Volume
VR7, 8	EVND4AA00B14	Overall Gain Adj.
VR301, 302	EVND4AA00B15	Bias Current Adj.
VR901-904	EVND1AA00B14	Tape Speed Adj.
<b>COMBINATION PART</b>		
Z801	EXBF7E562J	5.6K $\Omega$ $\times$ 6
<b>SWITCHES</b>		
S1, 801, 802	SSH3702	NR Editing Switch
S601	SSH1069	Power Switch
S901-906	SSP83	Leaf Switch
S907-909	LSA-1150AU	Leaf Switch

## SCHEMATIC DIAGRAM

- Notes:**
- S1 : Dolby NR switch in "out" position.
  - S601 : Power switch in "off" position.
  - S801 : Editing switch in "off" position.
  - S802 : Editing tape speed select switch in "Normal" position.
  - S901 : Tape 2 play switch in "off" position.
  - S902 : Tape 1 play switch in "off" position.
  - S903 : Tape 2 motor switch in "off" position.
  - S904 : Tape 1 motor switch in "off" position.
  - S905 : Tape 2 rec switch in "off" position.
  - S906 : Tape 1 FF/REW switch in "off" position.
  - S907 : Tape 2 Normal switch in "off" position.
  - S908 : Tape 2 CrO<sub>2</sub> switch in "off" position.
  - S909 : Tape 1 70 $\mu$ S switch in "off" position.

- Resistance are in ohms ( $\Omega$ ), 1/4 watt unless specified otherwise. 1K=1,000( $\Omega$ ), 1M=1,000k( $\Omega$ )
- Capacity are in micro-farads ( $\mu$ F) unless specified otherwise.
- All voltage values shown in circuitry are under no signal condition and Tape 2 playback mode with volume control at minimum position otherwise specified.
- ( ) ..... Voltage values at record mode.
- CrO<sub>2</sub> ..... Voltage values at CrO<sub>2</sub> tape mode.
- Metal ..... Voltage values at Metal tape mode.
- NR ..... Voltage values at Dolby NR mode.
- edi ..... Voltage values at editing mode.

- For measurement use EVM.
- ( ) indicates B (bias).
  - ( $\rightarrow$ ) indicates the flow of the playback signal.
  - ( $\leftarrow$ ) indicates the flow of the record signal.

### \* Caution !

- IC and LSI are sensitive to static electricity. Secondary trouble can be prevented by taking care during repair.
- Cover the parts boxes made of plastics with aluminum foil.
  - Ground the soldering iron.
  - Put a conductive mat on the work table.
  - Do not touch the legs of IC or LSI with the fingers directly.

## EQUIVALENT CIRCUIT

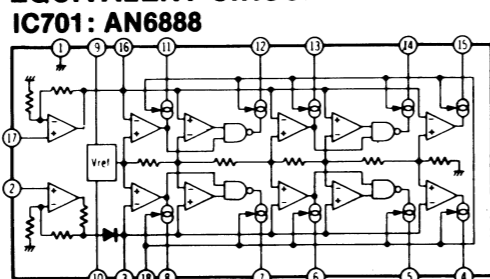

### SPECIFICATIONS \* Input level control... MAX

Playback S/N ratio * Test tape... QZZCFM	Greater than 45dB
Overall distortion * Test tape ... QZZCRA for Normal ... QZZCRX for CrO <sub>2</sub> ... QZZCRZ for Metal	Normal ..... Less than 3.5% CrO <sub>2</sub> , Metal... Less than 4%
Overall S/N ratio * Test tape... QZZCRA	Greater than 43dB (without NAB filter)

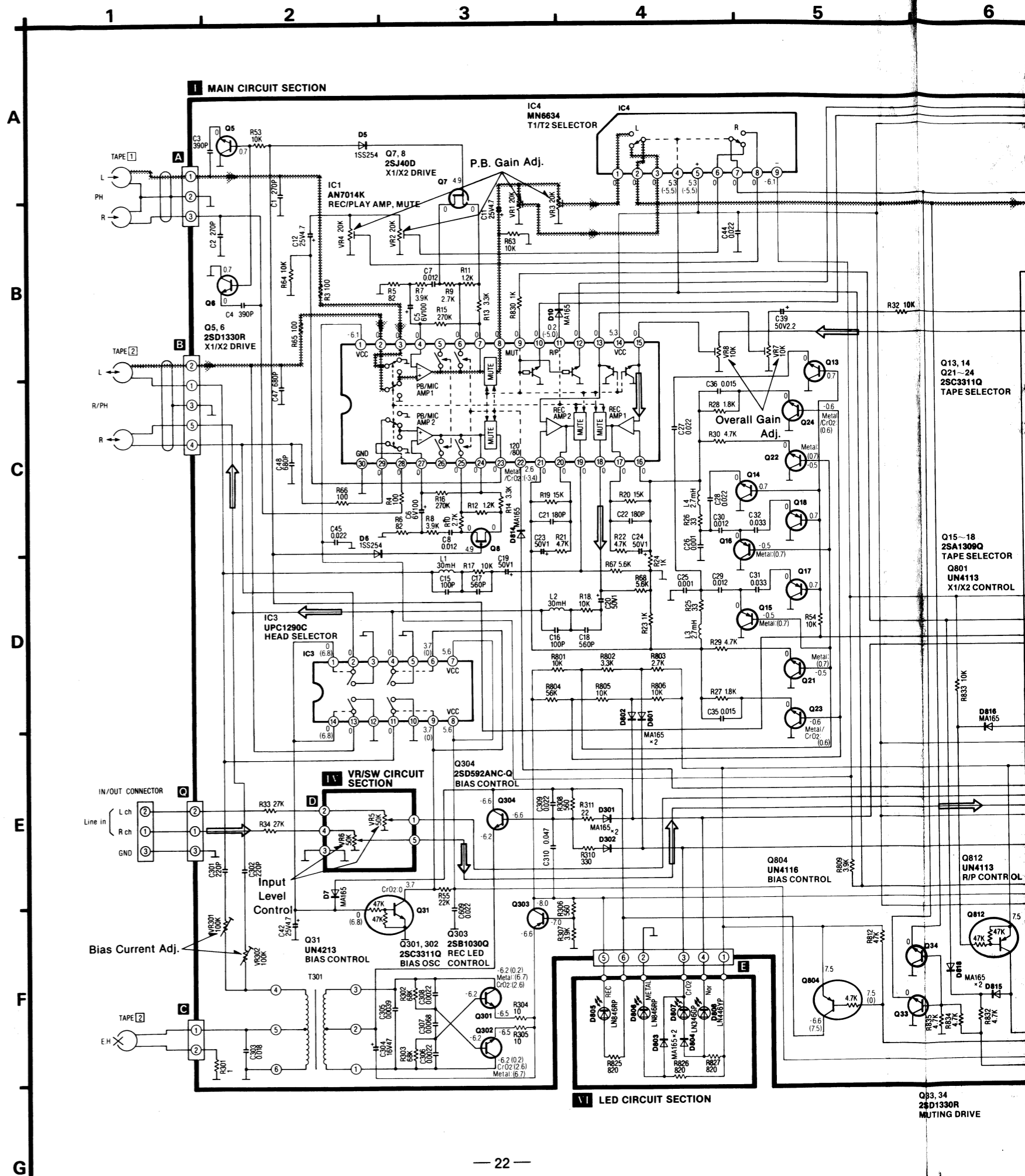

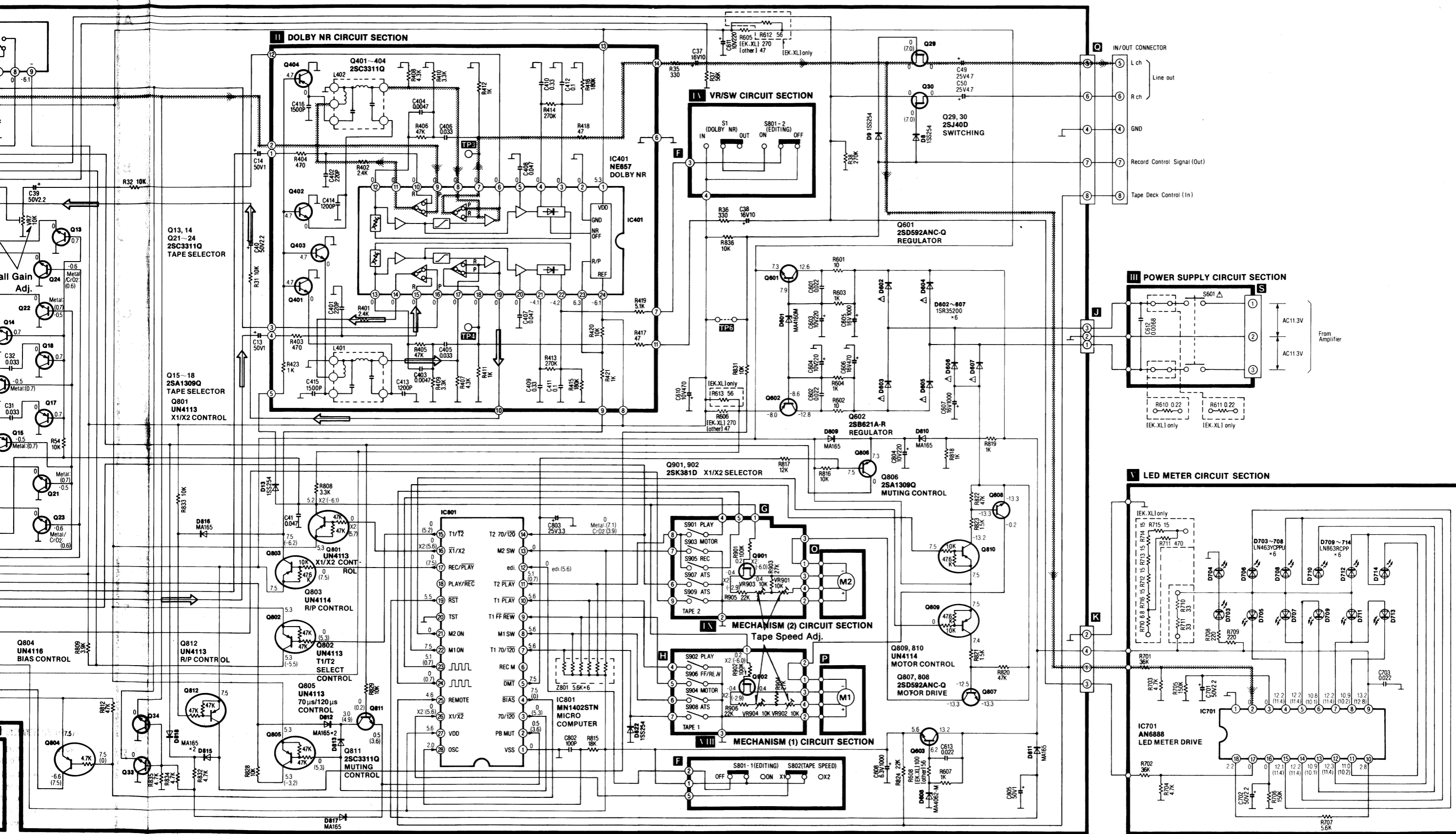

Q83, 34  
2A1330R  
MUTING DRIVE

VR/SW CIRCUIT SECTION

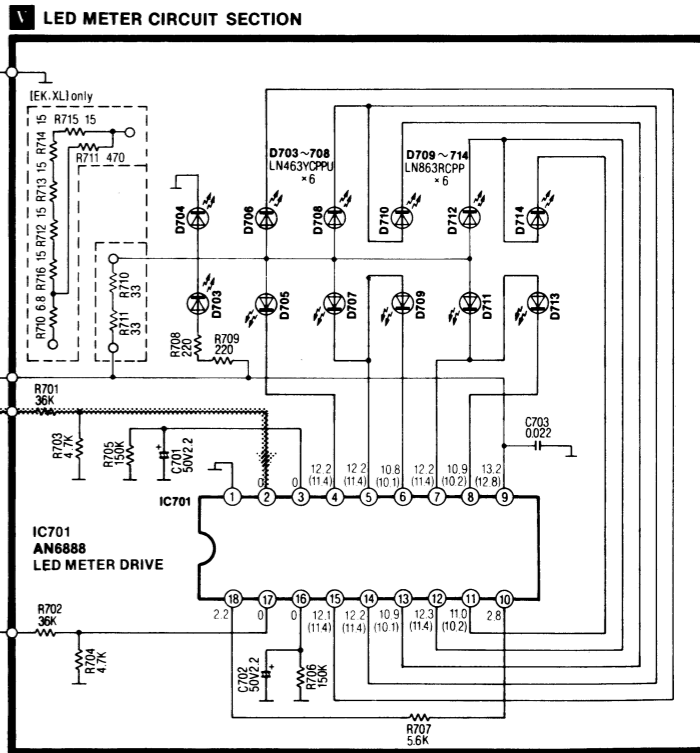
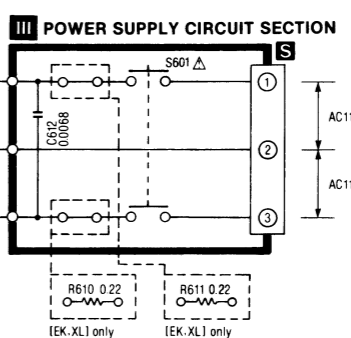
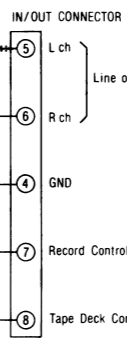



**■ CABINET PARTS LOCATION**

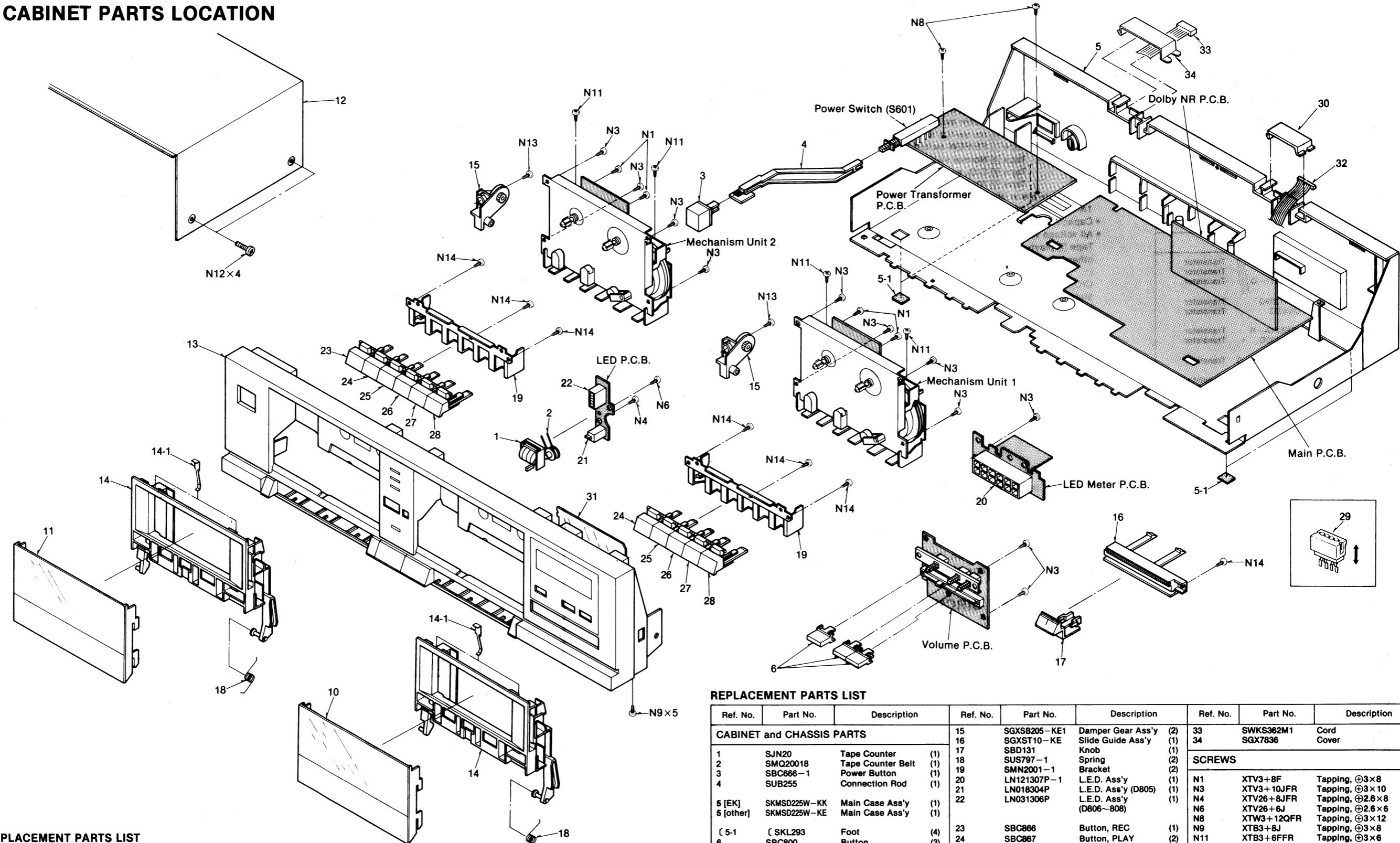

Part No.	Description	Quantity
1	2x8	(4)
2	2x7	(4)
3	2φ	(2)
4	2x4	(4)
5	2x5	(2)
6	2x5	(2)
7	2x6	(2)
8	1.5φ Special Washer	(4)
9	2φ Washer	(6)
10	2.2φ	(2)
11	2.0φ	(4)
12	2.6x6	(2)
13	1.5φ Washer	(2)
14	2x3	(6)
15	2.6x3 Washer	(2)
16	5	(2)
17	2x5	(4)
18	2x5	(4)
19	2x5	(4)
20	2x5	(4)
21	2x5	(4)
22	2x5	(4)
23	2x5	(4)
24	2x5	(4)
25	2x5	(4)
26	2x5	(4)
27	2x5	(4)
28	2x5	(4)
29	2x5	(4)
30	2x5	(4)
31	2x5	(4)
32	2x5	(4)
33	2x5	(4)
34	2x5	(4)

**REPLACEMENT PARTS LIST**

- Notes:**
- Part numbers are indicated on most mechanical parts. Please use this part number for parts order.
  - Bracketed indications in Ref. No. columns specify the area. Parts without these indications can be used for all areas.
  - The parenthesized numbers in the column of description stand for the quantity per set.

**REPLACEMENT PARTS LIST**

Ref. No.	Part No.	Description	Ref. No.	Part No.	Description	Ref. No.	Part No.	Description
<b>CABINET and CHASSIS PARTS</b>								
1	SJN20	Tape Counter (1)	15	SGXS8205-KE1	Damper Gear Ass'y (2)	33	SWKS362M1	Cord (1)
2	SMQ20018	Tape Counter Belt (1)	16	SGXST10-KE	Slide Guide Ass'y (1)	34	SGX7836	Cord Cover (1)
3	SBC666-1	Power Button (1)	17	SBD131	Knob (1)	<b>SCREWS</b>		
4	SUB255	Connection Rod (1)	18	SUS797-1	Spring (2)	N1	XTV3+8F	Tapping, ∅3x8 (4)
5 [EK]	SKMSD225W-KK	Main Case Ass'y (1)	19	SMN2001-1	Bracket (2)	N3	XTV3+10JFR	Tapping, ∅3x10 (11)
5 [other]	SKMSD225W-KE	Main Case Ass'y (1)	20	LN121307P-1	L.E.D. Ass'y (1)	N4	XTV26+8JFR	Tapping, ∅2.6x8 (1)
6	SBC800	Button (3)	21	LN018304P	L.E.D. Ass'y (D805) (1)	N6	XTV26+6J	Tapping, ∅2.6x6 (1)
10	SGE1790	Cassette Lid (Tape 1) (1)	22	LN031306P	L.E.D. Ass'y (D806-808) (1)	N8	XTW3+12QFR	Tapping, ∅3x12 (2)
11	SGE1791	Cassette Lid (Tape 2) (1)	23	SBC866	Button, REC (1)	N9	XTB3+8J	Tapping, ∅3x8 (5)
12	SKC1940K99	Cabinet (1)	24	SBC867	Button, PLAY (2)	N11	XTB3+6FFR	Tapping, ∅3x6 (4)
13 [EK]	SGYSD225W-KK	Front Panel Ass'y (1)	25	SBC868	Button, REW (2)	N12	SNE2125-1	Cabinet (4)
13 [other]	SGYSD225W-KE	Front Panel Ass'y (1)	26	SBC869	Button, FF (2)	N13	XTV3+12J	Tapping, ∅3x12 (2)
14	SGXSD225W-KM	Cassette Holder Ass'y (2)	27	SBC870	Button, STOP (2)	N14	XTV26+8J	Tapping, ∅2.6x8 (7)
14-1	QBP2006A	Tape Pressure Spring (4)	28	SBC871	Button, PAUSE (2)	<b>PACKING PARTS</b>		
			29	SJT30443-V	Socket, J □ (1)	P1 [EK]	SPG5689	Carton Box (1)
			29	SJT30543-V	Socket, J □, □ (2)	P1 [other]	SPG5690	Carton Box (1)
			29	SJT30643-V	Socket, J □ (1)	P2	SPS4705	Cushion (L) (1)
			29	SJT30743-V	Socket, J □ (1)	P3	SPS4706	Cushion (R) (1)
			29	SJT30943-V	Socket, J □ (1)	P4	SPS4753	Cushion (C) (1)
			30	SGX7835	Cover (1)	P5	XZB50X65A02	Poly Bag (1)
			31	SGX7847-1	Filter (1)	P6	SPS4734	Spacer (1)
			32	SWKSD225W-KM	Cord (1)			